

TRD-NA Series

Features

φ50 Absolute Type

- Ultracompact design with an outside diameter of φ50 mm / depth of 35 mm
- Thoroughly strengthened dustproof and waterjet-proof type with robust aluminum die-cast cover
- High axial load due to the strengthened spindle of φ8 mm stainless steel shaft.
- Gray code output that eliminates reading errors
- Use of a metal slit board delivers an impact resistance of 980 m/s².

(2,048 pulses for glass slit board)



Model Number List

NPN Output

Resolution	Output Increasing Rotation Direction	With Cable		With Relay Connector	With the connector for FC2 connection (For FC)	
		Cable Length 2 m	Cable Length 5 m	Cable Length 2 m	Cable Length 2 m	Cable Length 5 m
32 (5-bit)	CW	TRD-NA32NW	TRD-NA32NW5M	TRD-NA32NWE	—	—
	CCW	TRD-NA32RNW	TRD-NA32RNW5M	TRD-NA32RNWE	—	—
64 (6-bit)	CW	TRD-NA64NW	TRD-NA64NW5M	TRD-NA64NWE	—	—
	CCW	TRD-NA64RNW	TRD-NA64RNW5M	TRD-NA64RNWE	—	—
128 (7-bit)	CW	TRD-NA128NW	TRD-NA128NW5M	TRD-NA128NWE	—	—
	CCW	TRD-NA128RNW	TRD-NA128RNW5M	TRD-NA128RNWE	—	—
180 (8-bit)	CW	TRD-NA180NW	TRD-NA180NW5M	TRD-NA180NWE	—	—
	CCW	TRD-NA180RNW	TRD-NA180RNW5M	TRD-NA180RNWE	—	—
256 (8-bit)	CW	TRD-NA256NW	TRD-NA256NW5M	TRD-NA256NWE	—	—
	CCW	TRD-NA256RNW	TRD-NA256RNW5M	TRD-NA256RNWE	—	—
360 (9-bit)	CW	TRD-NA360NW	TRD-NA360NW5M	TRD-NA360NWE	TRD-NA360NWF2 (TRD-NA360NWF)	TRD-NA360NWF2-5M (TRD-NA360NWF5M)
	CCW	TRD-NA360RNW	TRD-NA360RNW5M	TRD-NA360RNWE	—	—
512 (9-bit)	CW	TRD-NA512NW	TRD-NA512NW5M	TRD-NA512NWE	—	—
	CCW	TRD-NA512RNW	TRD-NA512RNW5M	TRD-NA512RNWE	—	—
720 (10-bit)	CW	TRD-NA720NW	TRD-NA720NW5M	TRD-NA720NWE	TRD-NA720NWF2 (TRD-NA720NWF)	TRD-NA720NWF2-5M (TRD-NA720NWF5M)
	CCW	TRD-NA720RNW	TRD-NA720RNW5M	TRD-NA720RNWE	—	—
1,024 (10-bit)	CW	TRD-NA1024NW	TRD-NA1024NW5M	TRD-NA1024NWE	—	—
	CCW	TRD-NA1024RNW	TRD-NA1024RNW5M	TRD-NA1024RNWE	—	—
2,048 (11-bit)	CW	TRD-NA2048NW	TRD-NA2048NW5M	TRD-NA2048NWE	—	—
	CCW	TRD-NA2048RNW	TRD-NA2048RNW5M	TRD-NA2048RNWE	—	—

PNP Output

Resolution	Output Increasing Rotation Direction	With Cable	With Relay Connector	
		Cable Length 2 m	Cable Length 5 m	Cable Length 2 m
32 (5-bit)	CW	TRD-NA32PW	TRD-NA32PW5M	TRD-NA32PWE
	CCW	TRD-NA32RPW	TRD-NA32RPW5M	TRD-NA32RPWE
64 (6-bit)	CW	TRD-NA64PW	TRD-NA64PW5M	TRD-NA64PWE
	CCW	TRD-NA64RPW	TRD-NA64RPW5M	TRD-NA64RPWE
128 (7-bit)	CW	TRD-NA128PW	TRD-NA128PW5M	TRD-NA128PWE
	CCW	TRD-NA128RPW	TRD-NA128RPW5M	TRD-NA128RPWE
180 (8-bit)	CW	TRD-NA180PW	TRD-NA180PW5M	TRD-NA180PWE
	CCW	TRD-NA180RPW	TRD-NA180RPW5M	TRD-NA180RPWE
256 (8-bit)	CW	TRD-NA256PW	TRD-NA256PW5M	TRD-NA256PWE
	CCW	TRD-NA256RPW	TRD-NA256RPW5M	TRD-NA256RPWE
360 (9-bit)	CW	TRD-NA360PW	TRD-NA360PW5M	TRD-NA360PWE
	CCW	TRD-NA360RPW	TRD-NA360RPW5M	TRD-NA360RPWE
512 (9-bit)	CW	TRD-NA512PW	TRD-NA512PW5M	TRD-NA512PWE
	CCW	TRD-NA512RPW	TRD-NA512RPW5M	TRD-NA512RPWE
720 (10-bit)	CW	TRD-NA720PW	TRD-NA720PW5M	TRD-NA720PWE
	CCW	TRD-NA720RPW	TRD-NA720RPW5M	TRD-NA720RPWE
1,024 (10-bit)	CW	TRD-NA1024PW	TRD-NA1024PW5M	TRD-NA1024PWE
	CCW	TRD-NA1024RPW	TRD-NA1024RPW5M	TRD-NA1024RPWE

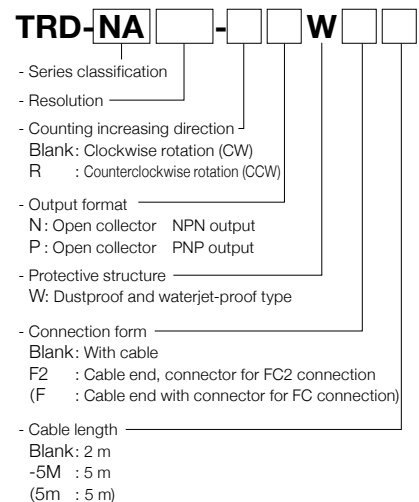

TRD-NA Series

Specifications

Electrical Specifications

Model Number	TRD-NA□NW		TRD-NA□PW	
Power Supply	Supply Voltage	10.8 to 26.4 V DC		
	Allowable Ripple	3% rms or less		
	Consumption Current*4	70 mA or lower (2,048 pulses: 100 mA or lower)	100 mA or lower	
Output Code	Gray binary*1		←	
Maximum Response Frequency	20 kHz*2		←	
Precision	(360/ (Resolution x 2))°		←	
Rotation Direction	Clockwise rotation (CW) or counterclockwise rotation (CCW)*3		←	
Output	Output Form	NPN open collector output		
	Output Logic	Negative logic (Active low)		
	Residual Voltage	0.4 V or lower	1.5 V or lower	0.5 V or lower
	Inflow-Outflow Current	16 mA	32 mA	30 mA
	Load Supply Voltage	30 V DC or lower		←
Rise / Fall Time*5	Not larger than 2.0 μs (Load resistance 1kΩ)		Not larger than 3.0 μs (Load resistance 1kΩ)	

*1: Excess 38 gray code for 180 resolution, excess 76 gray code for 360 resolution, and excess 152 gray code for 720 resolution

*2: Electrical maximum number of revolutions = ((Maximum response frequency/Resolution) x 60)

Therefore, if the encoder rotates at a speed greater than the electrical maximum number of revolutions, the signals do not electrically follow.

*3: CW means clockwise seen from the shaft side. CCW means counterclockwise seen from the shaft side.

*4: No load

*5: Cable length 2 m, maximum load

Mechanical Specifications

Starting Torque	0.02 N·m or less (+20°C)
Moment of Inertia	2 x 10 ⁻⁶ kg·m ²
Shaft Allowable Load	Radial: 50 N
	Thrust: 30 N
Maximum Allowable Number of Revolutions (Note 1)	3,000 rpm (Continuously)
	5,000 rpm (Instantaneously)
Cable	Outside diameter ϕ 7 mm
	12-core shielded oil-resistant vinyl chloride cable (1,024 or less)
	13-core shielded oil-resistant vinyl chloride cable (2,048)
	Core wire nominal cross-sectional area: 0.14 mm ²
Weight	Approx. 300 g (With 2 m cable)

Note 1: Maximum number of revolutions that can be mechanically endured

Environmental Requirements

Use Ambient Temperature	-10 to +60°C
Storage Ambient Temperature	-25 to +85°C
Use / Storage Ambient Humidity	25 to 85% RH (No condensation)
Withstand Voltage	Excluded due to capacitor grounding*
Insulation Resistance	10 MΩ or higher*
Vibration Resistance (Endurance)	Displacement half amplitude: 0.75 mm or less, 10 to 55 Hz, 3 axial directions, each 1 h
Impact Resistance (Endurance)	980 m/s ² 11 ms, each 3 times in 3 axial directions
Protective Structure	IP65 (Dustproof and waterjet-proof type)

* The power supply, signal lines, and shield between the cases are excluded.

Output Circuit

NPN Output

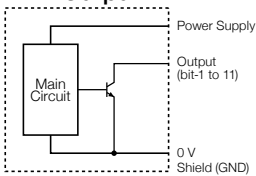

PNP Output

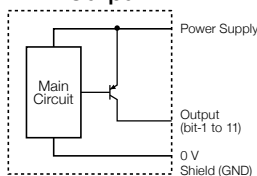

Home Position

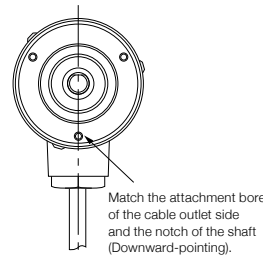

Bearing Life

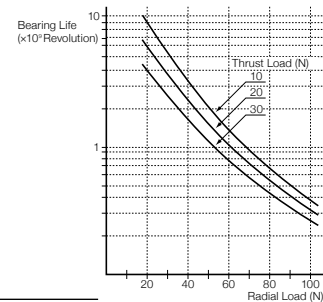

Connection

Cable Type Core Wire Color	Connector Type Pin No.	2,048 Resolution	1,024/720 Resolution	512/360 Resolution	256/180 Resolution	128 Resolution	64 Resolution	32 Resolution
Blue	1	0 V	0 V	←	←	←	←	←
Brown	2	+12/24 V	+12/24 V	←	←	←	←	←
Black	3	bit 1 (2 ⁰)	bit 1 (2 ⁰)	Not connected	←	←	←	←
Red	4	bit 2 (2 ¹)	bit 2 (2 ¹)	bit 1 (2 ⁰)	Not connected	←	←	←
Orange	5	bit 3 (2 ²)	bit 3 (2 ²)	bit 2 (2 ¹)	bit 1 (2 ⁰)	Not connected	←	←
Yellow	6	bit 4 (2 ³)	bit 4 (2 ³)	bit 3 (2 ²)	bit 2 (2 ¹)	bit 1 (2 ⁰)	Not connected	←
Green	7	bit 5 (2 ⁴)	bit 5 (2 ⁴)	bit 4 (2 ³)	bit 3 (2 ²)	bit 2 (2 ¹)	bit 1 (2 ⁰)	Not connected
Purple	8	bit 6 (2 ⁵)	bit 6 (2 ⁵)	bit 5 (2 ⁴)	bit 4 (2 ³)	bit 3 (2 ²)	bit 2 (2 ¹)	bit 1 (2 ⁰)
Gray	9	bit 7 (2 ⁶)	bit 7 (2 ⁶)	bit 6 (2 ⁵)	bit 5 (2 ⁴)	bit 4 (2 ³)	bit 3 (2 ²)	bit 2 (2 ¹)
White	10	bit 8 (2 ⁷)	bit 8 (2 ⁷)	bit 7 (2 ⁶)	bit 6 (2 ⁵)	bit 5 (2 ⁴)	bit 4 (2 ³)	bit 3 (2 ²)
Black / White	11	bit 9 (2 ⁸)	bit 9 (2 ⁸)	bit 8 (2 ⁷)	bit 7 (2 ⁶)	bit 6 (2 ⁵)	bit 5 (2 ⁴)	bit 4 (2 ³)
Red / white	12	bit 10 (2 ⁹)	bit 10 (2 ⁹)	bit 9 (2 ⁸)	bit 8 (2 ⁷)	bit 7 (2 ⁶)	bit 6 (2 ⁵)	bit 5 (2 ⁴)
Orange / white	13	bit 11 (2 ¹⁰)	Not connected	←	←	←	←	←
Shield	—	GND	GND	←	←	←	←	←

* The parenthesis marks the bit corresponding to the binary code. ★: Most significant bit

Connector
<Pin Assignment Figure>

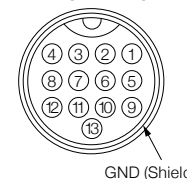

* Figure Seen from Wiring Side (Back side)

TRD-NA Series

Dimensions

Dimensions (Unit: mm)

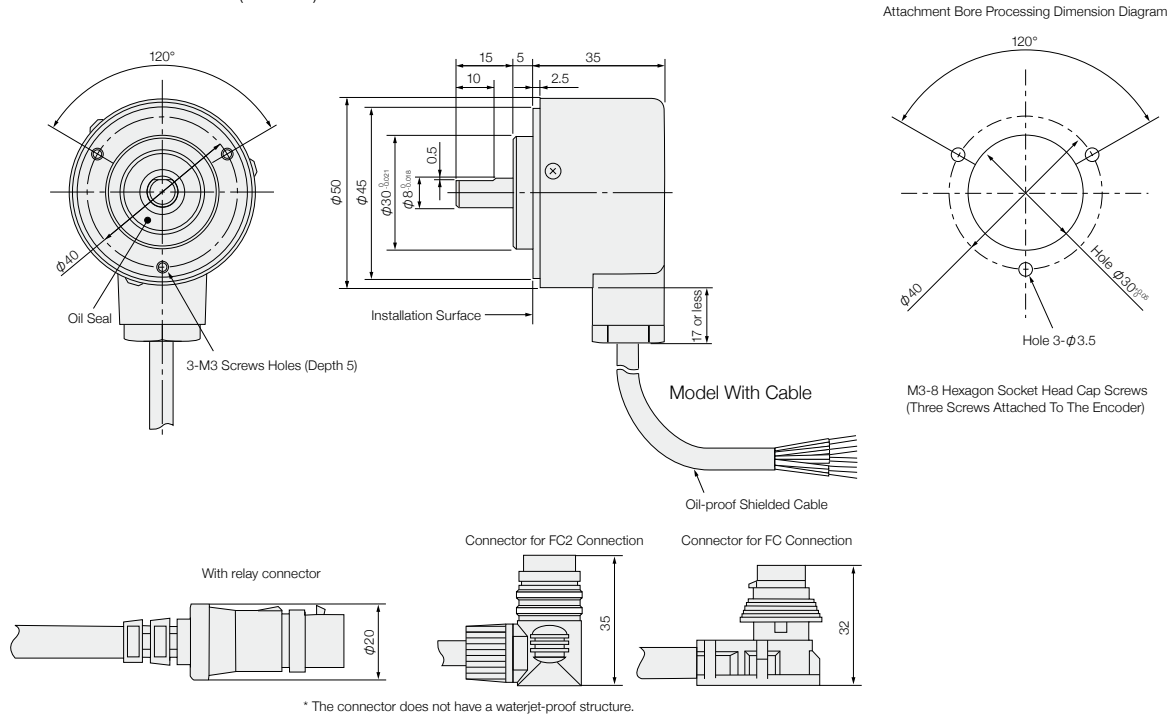

Servo Mount Metal Mounting State Diagram

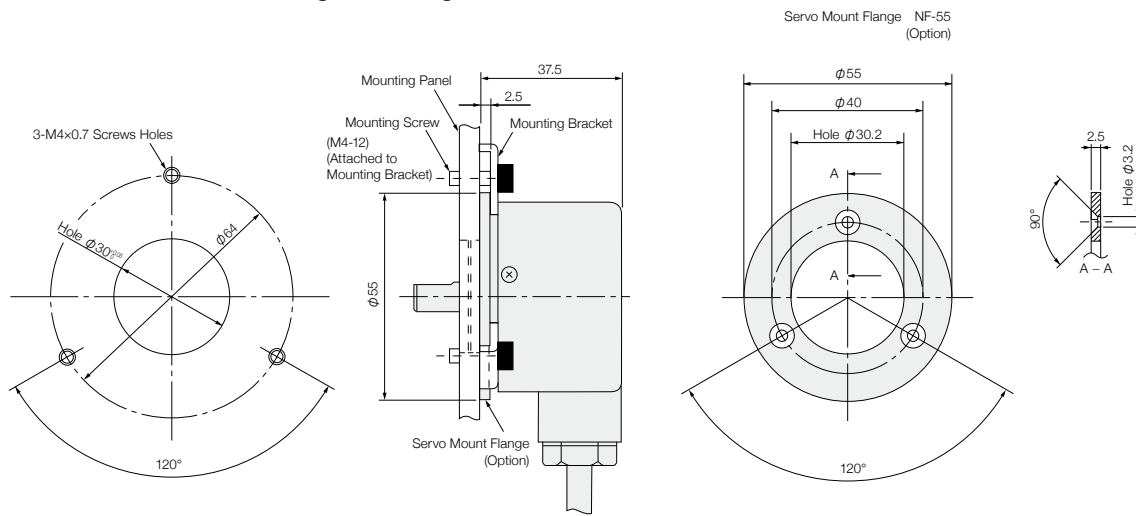

Servo Mount Metal Fixture
KM-9
(Attached to the Optional Flange)

