

Changes for the Better

DSS/DS

HARDWARE MANUAL

FX₂NC (DSS/DS) SERIES PROGRAMMABLE CONTROLLERS

FX₂NC



info@elinc.ru +7 (812) 7-03
www.e

Foreword

- This manual contains text, diagrams and explanations which will guide the reader in the correct installation and operation of the FX2NC. It should be read and understood before attempting to install or use the unit.
- Further information can be found in the FX2NC Series Hardware Manual and FX Series Programming Manual II.
- If in doubt at any stage of the installation of FX2NC always consult a professional electrical engineer who is qualified and trained to the local and national standards that applies to the installation site.
- If in doubt about the operation or use of FX2NC please consult the nearest Mitsubishi Electric distributor.
- This manual is subject to change without notice.



FX2NC (DSS/DS) Series Programmable Controllers

Hardware Manual

Manual number : JY992D76401

Manual revision : G

Date : November 2005

This manual confers no industrial property rights or any rights of any other kind, nor does it confer any patent licenses. Mitsubishi Electric Corporation cannot be held responsible for any problems involving industrial property rights which may occur as a result of using the contents noted in this manual.

Guidelines for the safety of the user and protection of the FX₂NC.

This manual provides information for the installation and use of the FX₂NC. The manual has been written to be used by trained and competent personnel. The definition of such a person or persons is as follows:

- a) Any engineer who is responsible for the planning, design and construction of automatic equipment using the product associated with this manual, should be of a competent nature, trained and qualified to the local and national standards required to fulfill that role. These engineers should be fully aware of all aspects of safety with regards to automated equipment.
- b) Any commissioning or service engineer must be of a competent nature, trained and qualified to the local and national standards required to fulfill that job. These engineers should also be trained in the use and maintenance of the completed product. This includes being completely familiar with all associated documentation for said product. All maintenance should be carried out in accordance with established safety practices.
- c) All operators of the completed equipment (see Note) should be trained to use this product in a safe manner in compliance to established safety practices. The operators should also be familiar with documentation which is associated with the actual operation of the completed equipment.

Note : The term ‘completed equipment’ refers to a third party constructed device which contains or uses the product associated with this manual.

Notes on the Symbols Used in this Manual

At various times throughout this manual certain symbols will be used to highlight points which are intended to ensure the users personal safety and protect the integrity of equipment. Whenever any of the following symbols are encountered its associated note must be read and understood. Each of the symbols used will now be listed with a brief description of its meaning.

Hardware warnings



1) Indicates that the identified danger **WILL** cause physical and property damage.



2) Indicates that the identified danger could **POSSIBLY** cause physical and property damage.



3) Indicates a point of further interest or further explanation.

Software warning



4) Indicates special care must be taken when using this element of software.



5) Indicates a special point which the user of the associate software element should be aware of.



6) Indicates a point of interest or further explanation.

- Under no circumstances will Mitsubishi Electric be liable responsible for any consequential damage that may arise as a result of the installation or use of this equipment.
- All examples and diagrams shown in this manual are intended only as an aid to understanding the text, not to guarantee operation. Mitsubishi Electric will accept no responsibility for actual use of the product based on these illustrative examples.
- Please contact a Mitsubishi Electric distributor for more information concerning applications in life critical situations or high reliability.

Note Concerning the CE Marking

This note does not guarantee that an entire mechanical module produced in accordance with the contents of this note will comply with the following standards. Compliance to EMC directive and LVD directive of the entire mechanical module should be checked by the user / manufacturer.

For more details please contact the local Mitsubishi Electric sales site.

EMC

The following products have shown compliance through direct testing (of the identified standards below) and design analysis (through the creation of a technical construction file) to the European Directive for Electromagnetic Compatibility (89/336/EEC) when used as directed by the appropriate documentation. Refer to a manual or related material of each product for details concerning products not included below.

Type : Programmable Controller (Open Type Equipment)

Models : MELSEC FX2NC series manufactured

from March 1st, 1999	FX2NC-☆☆MT-DSS	Where ☆☆ indicates:16,32,64,96
	FX2NC-☆☆EX-DS	FX2NC-☆☆EYT-DSS
	Where ☆☆ indicates:16,32	
	FX2NC-EEPROM-16	FX2NC-RTC
	FX2NC-EEPROM-4C	FX2NC-EEPROM16C
from August 1st, 1999	FX2NC-16MR-T-DS	
	FX2NC-16EX-T-DS	FX2NC-16EYR-T-DS
from July 1st, 2001	FX2NC-ROM-CE1	
from October 1st, 2002	FX2NC-232ADP	FX2NC-485ADP

Models : MELSEC FX0N series manufactured

from November 1st, 1995	FX0N-8EX-ES,	FX0N-8EYR-ES,	FX0N-8EYT-ESS
from February 1st, 1996	FX0N-8ER-ES,	FX0N-16EX-ES,	FX0N-16EYR-ES,
	FX0N-16EYT-ESS		
from April 1st, 1996	FX0N-8ER-ES/UL,	FX0N-16EX-ES/UL,	FX0N-16EYR-ES/UL,
	FX0N-16EYT-ESS/UL		
from May 1st, 1996	FX0N-232ADP	FX0N-485ADP	
from July 1st, 1996	Harmonized Products		
	FX0N-8EX-ES/UL,	FX0N-8EYR-ES/UL,	FX0N-8EYT-ESS/UL

Standard		Remark
EN50081-2:1993 EN61000-6-4:2001	Electromagnetic compatibility - Generic emission standard Industrial environment	Compliance with all relevant aspects of the standard. (Radiated Emissions and Mains Terminal Voltage Emissions)
EN61000-6-2:2001	Electromagnetic compatibility - Generic immunity standard Industrial environment	Compliance with all relevant aspects of the standard. (RF immunity, Fast Transients, ESD, Conducted, Surge, Power magnetic fields, Voltage dips and Voltage interruptions)

Models : MELSEC FX2N series manufactured

from July 1st, 1997 FX2N-16EX-ES/UL FX2N-16EYR-ES/UL FX2N-16EYT-ESS/UL

from August 1st, 2005 FX2N-8ER-ES/UL FX2N-8EX-ES/UL
FX2N-8EYR-ES/UL FX2N-8EYT-ESS/UL

to March 31st,2002 [compliance with EN50081-2 (EN61000-6-4) and EN50082-2]

from April 1st 2002:Above mentioned products [compliance with EN50081-2
(EN61000-6-4) and EN61131-2]

Standard	Remark
EN50081-2:1993 EN61000-6-4 :2001 Electromagnetic compatibility -Generic emission standard Industrial environment	Compliance with all relevant aspects of the standard. (Radiated Emissions and Mains Terminal Voltage Emissions)
EN50082-2:1995 Electromagnetic compatibility - Generic immunity standard Industrial environment	Compliance with all relevant aspects of the standard. (RF immunity, Fast Transients, ESD, Conducted, and Power magnetic fields)
EN61131-2:1994 /A11:1996 /A12:2000 Programmable controllers - Equipment requirements and tests	Compliance with all relevant aspects of the standard. (RF Immunity, Fast Transients , ESD and Damped oscillatory wave)

Note : When using the FX2NC-64MT-DSS,FX2NC-96MT-DSS,FX2NC-16EYT-DSS and FX2NC-32EYT-DSS.

Please use cable 30m or less for the following outputs to comply with the above mentioned identified standards/directives.

- Outputs Y20-Y37 of FX2NC-64MT-DSS
- Outputs Y20-Y57 of FX2NC-96MT-DSS
- All outputs of FX2NC-16EYT-DSS and FX2NC-32EYT-DSS

LVD

The following products have shown compliance through direct testing (of the identified standards below) and design analysis (through the creation of a technical construction file) to the European Directive for Low Voltage (73/23/EEC) when used as directed by the appropriate documentation.

Refer to a manual or related material of each product for details concerning products not included below.

Type : Programmable Controller (Open Type Equipment)

Models : MELSEC FX2NC series manufactured
 from August 1st, 1999 FX2NC-16MR-T-DS
 FX2NC-16EYR-T-DS

Standard		Remark
IEC1010-1:1990 /A1:1992 BSEN61010-1 :1993 *	Safety requirements for electrical equipment for measurement, control and laboratory use - General requirements	The equipment has been assessed as a component for fitting in a suitable enclosure which meets the requirements of IEC 1010-1:1990+A1:1992

* Compliance to BSEN61010-1 is claimed through virtue of direct compliance to IEC1010-1 and Amendment 1.

Models : MELSEC FX2N series manufactured
 from July 1st, 1997 FX2N-16EYR-ES/UL
 from August 1st, 2005 FX2N-8ER-ES/UL FX2N-8EYR-ES/UL
 to March 31st,2002(compliance with IEC1010-2+A1)
 from April 1st 2002:Above mentioned products(compliance with EN61131-2)

Standard	Remark
IEC1010-1:1990 Safety requirements for electrical /A1:1992 equipment for measurement, control,and laboratory use - General requirements	The equipment has been assessed as a component for fitting in a suitable enclosure which meets the requirements of IEC 1010-1:1990+A1:1992
EN61131-2:1994 Programmable controllers /A11:1996 - Equipment requirements and /A12:2000 tests	The equipment has been assessed as a component for fitting in a suitable enclosure which meets the requirements of EN61131-2:1994+A11:1996+A12:2000

Models : MELSEC FX0N series manufactured

from November 1st, 1995 FX0N-8EX-ES, FX0N-8EYR-ES, FX0N-8EYT-ESS

from February 1st, 1996 FX0N-8ER-ES, FX0N-16EX-ES, FX0N-16EYR-ES,
FX0N-16EYT-ESS

from April 1st, 1996 FX0N-8ER-ES/UL, FX0N-16EX-ES/UL, FX0N-16EYR-ES/UL,
FX0N-16EYT-ESS/UL

from July 1st, 1996 Harmonized Products
FX0N-8EX-ES/UL, FX0N-8EYR-ES/UL, FX0N-8EYT-ESS/UL

Standard	Remark
IEC1010-1:1990 Safety requirements for electrical /A1:1992 equipment for measurement, /A2:1995 control, and laboratory use BSEN61010-1 :1993 * /A2:1995	The equipment has been assessed as a component for fitting in a suitable enclosure which meets the requirements of IEC 1010-1:1990, A1:1992 and A2:1995(BSEN61010-1 :1993 and A2:1995)

* Compliance to BSEN61010-1 and Amendment2 is claimed through virtue of direct compliance to IEC1010-1 ,Amendment 1 and Amendment 2.

Guideline.....	ii
1. Introduction	1-1
1.1 Unit accessories.....	1-10
1.2 World Spec.	1-10
1.3 Model name	1-11
1.4 Serial numbers	1-12
1.5 Configuration.....	1-13
1.5.1 Summary	1-15
1.5.2 Current consumption and input/output points.....	1-17
1.5.3 Rules	1-21
1.5.4 System configuration example	1-24
1.5.5 Quick judgment	1-27
2. Terminal layouts.....	2-1
2.1 Main units.....	2-1
2.2 FX2NC Extension blocks	2-3
2.3 FX2N and FX0N Extension blocks	2-4
3. Installation notes	3-1
3.1 Product outline	3-2
3.2 FX2NC RUN/STOP Control	3-4
3.3 General specifications.....	3-6
3.4 PLC mounting arrangements	3-7
3.5 Connection of extension blocks to main unit.....	3-9
3.6 DIN rail mounting	3-9
3.7 Direct mounting	3-10
3.8 Extension cable installation.....	3-13

3.9	General notes	3-14
3.10	Memory Board installation	3-15
3.11	Wiring techniques	3-16
3.12	Termination of connector style I/O	3-17
3.13	Termination of Terminal style I/O	3-17
3.14	Termination of screw terminals	3-20
3.15	Termination of connector style I/O cables	3-21
4.	Power supply	4-1
4.1	Power supply cautions	4-4
4.2	Earthing / Grounding	4-6
5.	Inputs	5-1
5.1	24V DC input specifications	5-1
5.1.1	Typical wiring	5-2
5.1.2	Input circuit connection	5-4
5.1.3	Diodes and inputs connected in series;	5-5
5.1.4	Resistors and inputs connected in parallel;	5-6
5.2	AC110V input Extension block	5-7
5.2.1	Input circuit connection	5-7
5.2.2	Programming caution	5-8

6.	Outputs	6-1
6.1	Transistor output specification	6-1
6.1.1	Response times.....	6-2
6.1.2	Transistor output example	6-3
6.2	Relay output specification	6-5
6.2.1	Reliability tests	6-6
6.2.2	Relay output example.....	6-7
6.3	Triac (SSR) output specifications.....	6-9
6.3.1	In-rush currents	6-10
6.3.2	Triac output example.....	6-11
6.4	Applying safe loads	6-11
7.	Diagnostics.....	7-1
7.1	Preliminary checks.....	7-1
7.2	Basic diagnostics	7-2
7.2.1	BATT LED ON.....	7-2
7.2.2	ERROR LED flashes (PROGRAM ERROR)	7-2
7.2.3	ERROR LED ON (CPU ERROR).....	7-3
7.3	Common errors	7-4
7.4	Replacing the battery	7-4
7.5	Maintenance	7-4
7.6	Error flags ON indicates error.	7-5
7.7	Error registers	7-7
7.8	Error codes	7-9
7.9	Instruction list.....	7-10

1	INTRODUCTION
2	TERMINAL LAYOUTS
3	INSTALLATION NOTES
4	POWER SUPPLY
5	INPUTS
6	OUTPUTS
7	DIAGNOSTICS

1. Introduction

This manual covers the hardware installation instructions for the following programmable controller (PLC) product ranges;

- FX2NC main units.
- FX2NC extension blocks and special function blocks

Table 1.1 : Main units

MODEL	INPUT		OUTPUT		POWER SUPPLY	DIMENSIONS mm (inches)			MASS kg (lbs)
	QTY	TYPE	QTY	TYPE					
FX2NC-16MT-DSS	8	24V DC Sink / Source	8	Transistor (Source)	24V DC +20% -15% Ripple Voltage (p-p) 5% or less	35 (1.4)	90 (3.5)	87 (3.4)	0.2 (0.44)
FX2NC-32MT-DSS	16		16					60 (2.4)	0.35 (0.77)
FX2NC-64MT-DSS	32		32					86 (3.4)	0.45 (0.99)
FX2NC-96MT-DSS	48		48						
FX2NC-16MR-T-DS	8		8	Relay		35 (1.4)	89 (3.5)		

Figure 1.1 :Main unit dimensions

UNITS: mm (inches)

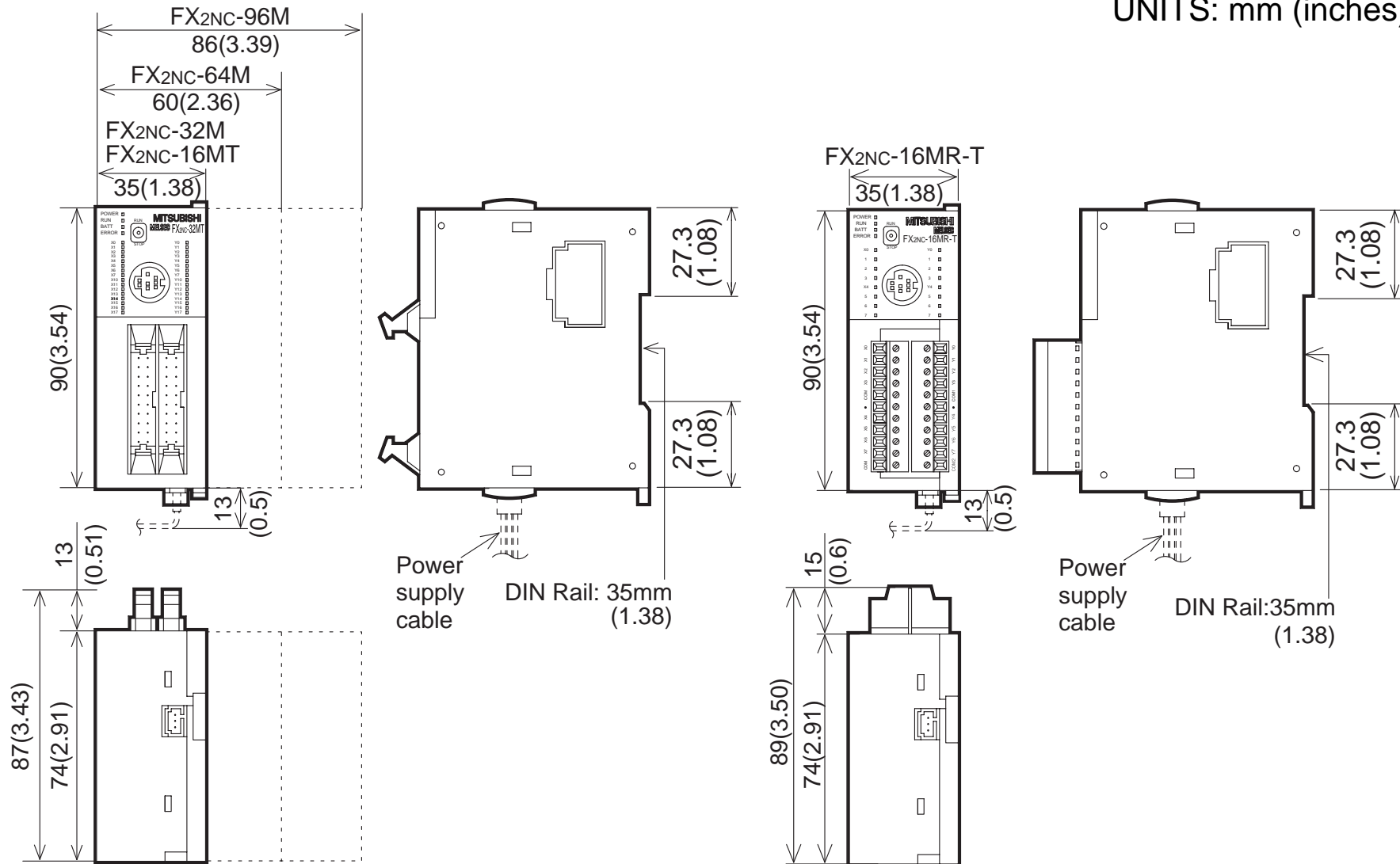

Table 1.2 : Extension blocks

MODEL	INPUT		OUTPUT			DIMENSIONS		MASS kg (lbs)	
	QTY	TYPE	QTY	DEVICE	TYPE	mm (inches)			
FX2NC-16EX-DS	16	24V DC Sink/ Source	-	-	-	14.6 (0.6)	90 (3.5)	87 (3.4)	0.15 (0.33)
FX2NC-16EYT-DSS	-	-	16	Transistor	Source				
FX2NC-32EX-DS	32	24V DC Sink/ Source	-	-	-	26.2 (1.0)	90 (3.5)	89 (3.5)	0.2 (0.44)
FX2NC-32EYT-DSS	-	-	32	Transistor	Source				
FX2NC-16EX-T-DS	16	24V DC Sink/ Source	-	-	-	20.2 (0.8)	90 (3.5)	89 (3.5)	0.2 (0.44)
FX2NC-16EYR-T-DS	-	-	16	Relay	-	24.2 (0.95)			

Table 1.2 : Extension blocks

MODEL	INPUT		OUTPUT			DIMENSIONS mm (inches)			MASS kg (lbs)
	QTY	TYPE	QTY	DEVICE	TYPE				
FX0N-8EX-UA1/UL FX2N-8EX-UA1/UL	8	110V AC inputs	-	-	-	43 (1.7)	90 (3.5)	87 (3.4)	0.2 (0.44)
FX0N-8EX-ES/UL FX2N-8EX-ES/UL	8	24V DC Sink/ Source	-	-	-				
FX0N-8ER-ES/UL FX2N-8ER-ES/UL	4		4	Relay	-				
FX0N-8EYR-ES/UL FX2N-8EYR-ES/UL	-	-	8		-				
FX0N-8EYT-ESS/UL FX2N-8EYT-ESS/UL	-	-	8	Transistor	Source				
FX0N-16EX-ES/UL	16	24V DC Sink/ Source	-	-	-	70 (2.8)			0.3 (0.66)
FX0N-16EYR-ES/UL	-	-	16	Relay	-				
FX0N-16EYT-ESS/UL	-	-	16	Transistor	Source				
FX2N-16EX-ES/UL	16	24V DC Sink/ Source	-	-	-	40 (1.6)	90 (3.5)	87 (3.4)	0.3 (0.66)
FX2N-16EYR-ES/UL	-	-	16	Relay	-				
FX2N-16EYT-ESS/UL	-	-	16	Transistor	Source				

Table 1.3 : Connector conversion adapter

MODEL	DESCRIPTION	DIMENSIONS mm (inches)			MASS kg (lbs)
FX2NC-CNV-IF	Extension blocks and special functions blocks of FX2N and FX0N are connected by this adapter	14.6 (0.6)	90 (3.5)	74 (2.9)	0.15 (0.33)

Figure 1.2 :Extension block dimensions

UNITS: mm (inches)

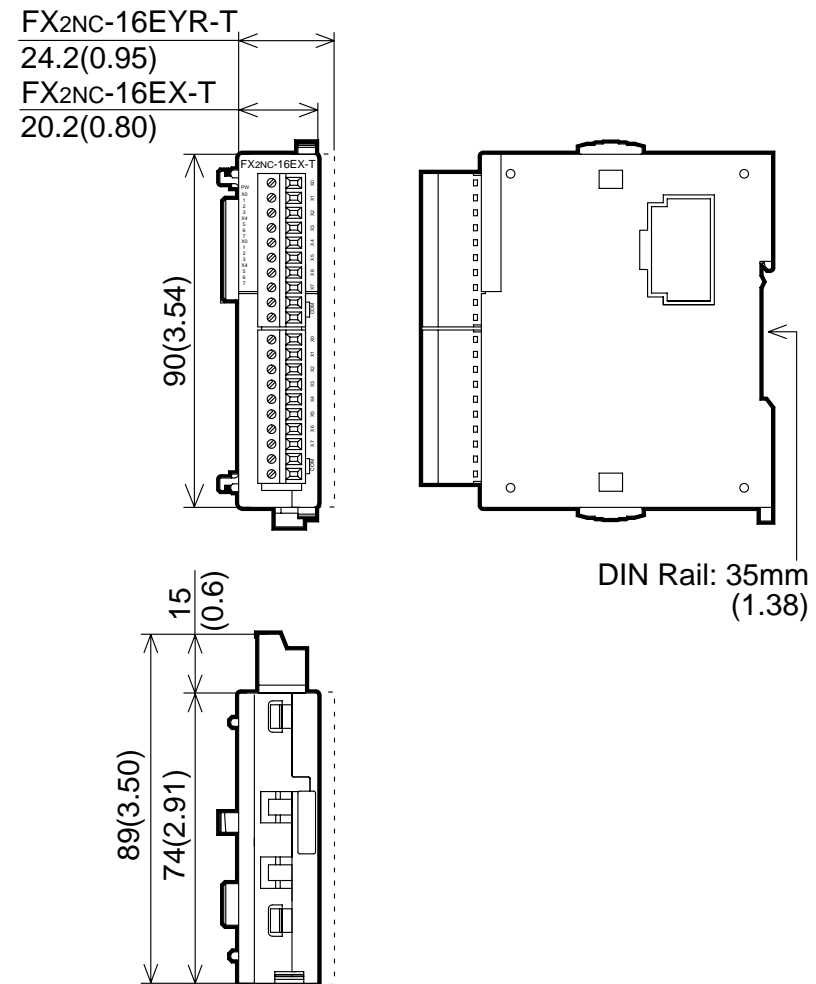
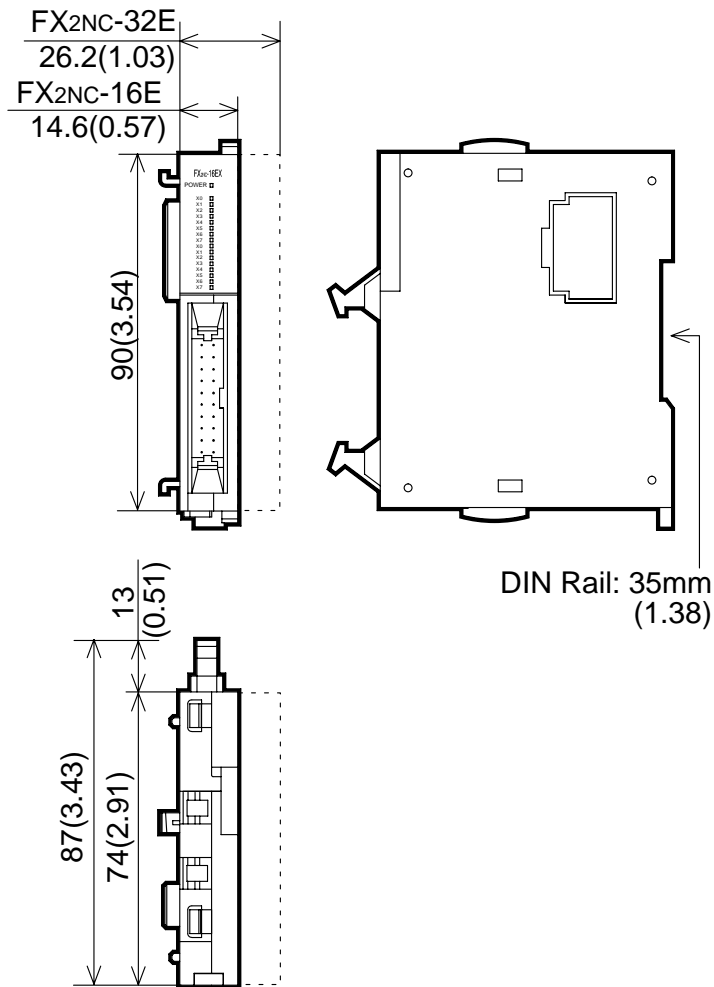

FX0N, FX2N Extension block dimensions →(See sec. 3.7)

Figure 1.3 :Connector conversion adapter

UNITS: mm (inches)

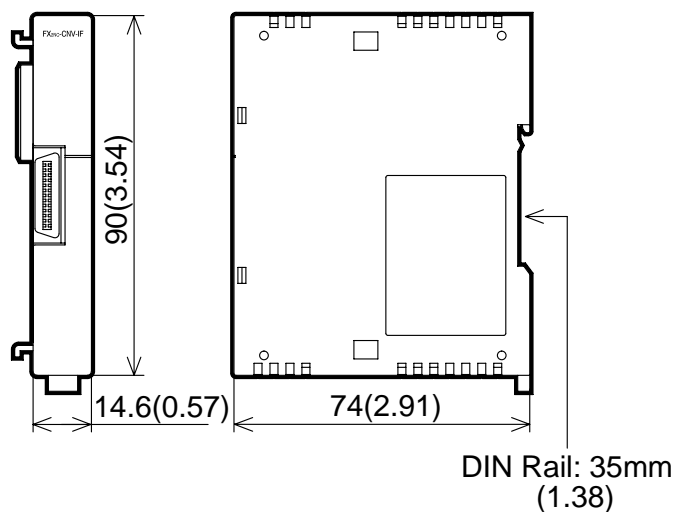

Table 1.4 :Special function blocks

MODEL	DESCRIPTION	NUMBER OF I/O			POWER SUPPLY		DIMENSIONS mm (inches)			MASS kg (lbs)
		I	O		Internal 5V DC	External 24V DC				
FX2N-2AD	Analog to digital converter	-	8	-	20mA	50mA*1	43 (1.7)	90 (3.5)	87 (3.4)	0.2(0.44)
FX2NC-4AD		-	8	-	50mA	130mA	20 (0.8)		89 (3.5)	0.13 (0.29)
FX2N-4AD		-	8	-	30mA	55mA	55 (2.1)		87 (3.4)	0.3(0.66)
FX2N-8AD		-	8	-	50mA	80mA	75 (2.9)		75 (2.9)	0.4(0.88)

Table 1.4 :Special function blocks

MODEL	DESCRIPTION	NUMBER OF I/O			POWER SUPPLY		DIMENSIONS mm (inches)			MASS kg (lbs)
		I	O		Internal 5V DC	External 24V DC				
FX0N-3A	Analog / Digital converter	-	8	-	30mA	90mA*1	43 (1.7)	90 (3.5)	87 (3.4)	0.2(0.44)
FX2N-5A		-	8	-	70mA	90mA	55 (2.1)			0.3(0.66)
FX2N-2DA	Digital to analog converter	-	8	-	30mA	85mA*1	43 (1.7)		0.2(0.44)	
FX2NC-4DA		-	8	-	30mA	130mA	24 (0.9)	89 (3.5)	0.13 (0.29)	
FX2N-4DA		-	8	-	30mA	200mA	55 (2.1)	87 (3.4)	0.3(0.66)	
FX2N-4AD-PT	PT 100 probe interface	-	8	-	30mA	50mA				
FX2N-4AD-TC	Thermo-couple interface	-	8	-	30mA	50mA				
FX2N-2LC	Temperature control	-	8	-	70mA	55mA				
FX2N-1HC	High speed counter	-	8	-	90mA	-	43 (1.7)	87 (3.4)	0.2(0.44)	
FX2N-1PG-E	Pulse output, Position control	-	8	-	55mA	40mA				
FX2N-10PG		-	8	-	120mA	70mA*2	60 (2.4)	0.3(0.66)		
FX2N-10GM	Positioning controller	-	8	-	-	5W	86 (3.4)	0.4(0.88)		
FX2N-20GM		-	8	-	-	10W	55 (2.1)	111 (4.4)	97 (3.8)	0.5(1.1)
FX2N-1RM-E-SET	Programmable cam switch	-	8	-	-	210mA	55 (2.1)	111 (4.4)	97 (3.8)	0.5(1.1)

Table 1.4 :Special function blocks

MODEL	DESCRIPTION	NUMBER OF I/O			POWER SUPPLY		DIMENSIONS mm (inches)		MASS kg (lbs)	
		I	O		Internal 5V DC	External 24V DC				
FX2N-232IF	RS-232C Interface block	-	8	-	40mA	80mA	55 (2.1)	90 (3.5)	87 (3.4)	0.3(0.66)
FX2N-16CCL-M	CC-Link Interface block	*3	8	*3	-	150mA	85 (3.3)			0.4(0.88)
FX2N-32CCL	CC-Link Interface block	-	8	-	130mA	50mA	43 (1.7)			0.2(0.44)
FX2N-64CL-M	CC-Link/LT Interface block	*4	8	*4	190mA	25mA*4				0.15 (0.01)
FX2N-16LNK-M	MELSEC-I/O LINK Remote I/O system master block	*5			200mA	90mA	0.5(1.1)			
FX0N-16NT	Net-mini interface	8	8		20mA	60mA	0.2(0.44)			

*1 : Internal 24V DC

*2 : When the voltage of the external DC power supply is 24V DC and 5V DC, the current is 70 mA and 100 mA, respectively.

*3 : Maximum number of I/O points per system Connection is allowed as far as the following condition is satisfied:

(Actual number of I/O points of PLC) + (Number of points occupied by special extension blocks) + (Number of points occupied by FX2N-16CCL-M: 8) + (32 x Number of remote I/O modules) ≤ 256

*4 : For details, refer to the FX2N-64CL-M user's manual.

*5 : The value depends on the switch setting.

1.1 Unit accessories

MPU-Main unit : FX₂NC-100MPCB power supply cables.

Extension block : I / O label kit.

1.2 World Spec.

Table 1.5 : World / Japanese Spec.

Input Sink / Source	World spec models : SINK / SOURCE. Japanese models : ALWAYS SINK.
Outputs Transistor	World spec models : ALWAYS SOURCE. Japanese models : ALWAYS SINK.

1.3 Model name

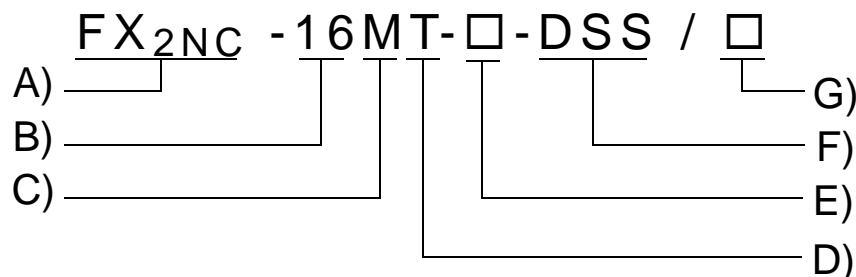

Table 1.6 : Model table

A)	PLC type : FX2NC, FX2N, FX0N
B)	Total number of I / O channels
Unit type	
C)	M MPU - main unit
	E Powered extension unit
	EX Extension block, input
	EY Extension block, output
Output type	
D)	R Relay
	S Triac (SSR)
	T Transistor

E)	T	Terminal style I/O. ,Only FX2NC.
Features		
F)	Omit	AC, Japanese spec.
	D	24V DC Japanese spec.
	DS	24V DC World spec.
	DSS	24V DC World spec., DC source transistor
	ES	AC Power Supply World spec.,DC sink transistor
	ESS	AC Power Supply World spec., DC source transistor
G)	UA1	AC Power Supply, AC inputs
	UL	CE,UL registered product

1.4 Serial numbers

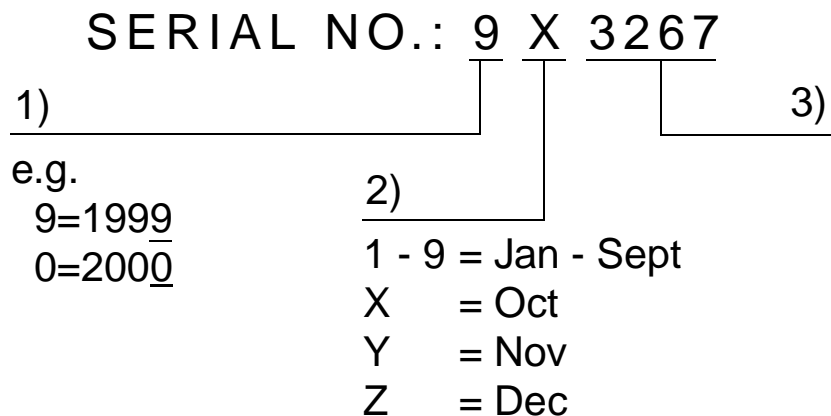

Table 1.7 : Notes on serial numbers

1)	Production year
2)	Production month
3)	Production serial number

1.5 Configuration

Figure 1.4 :Schematic system

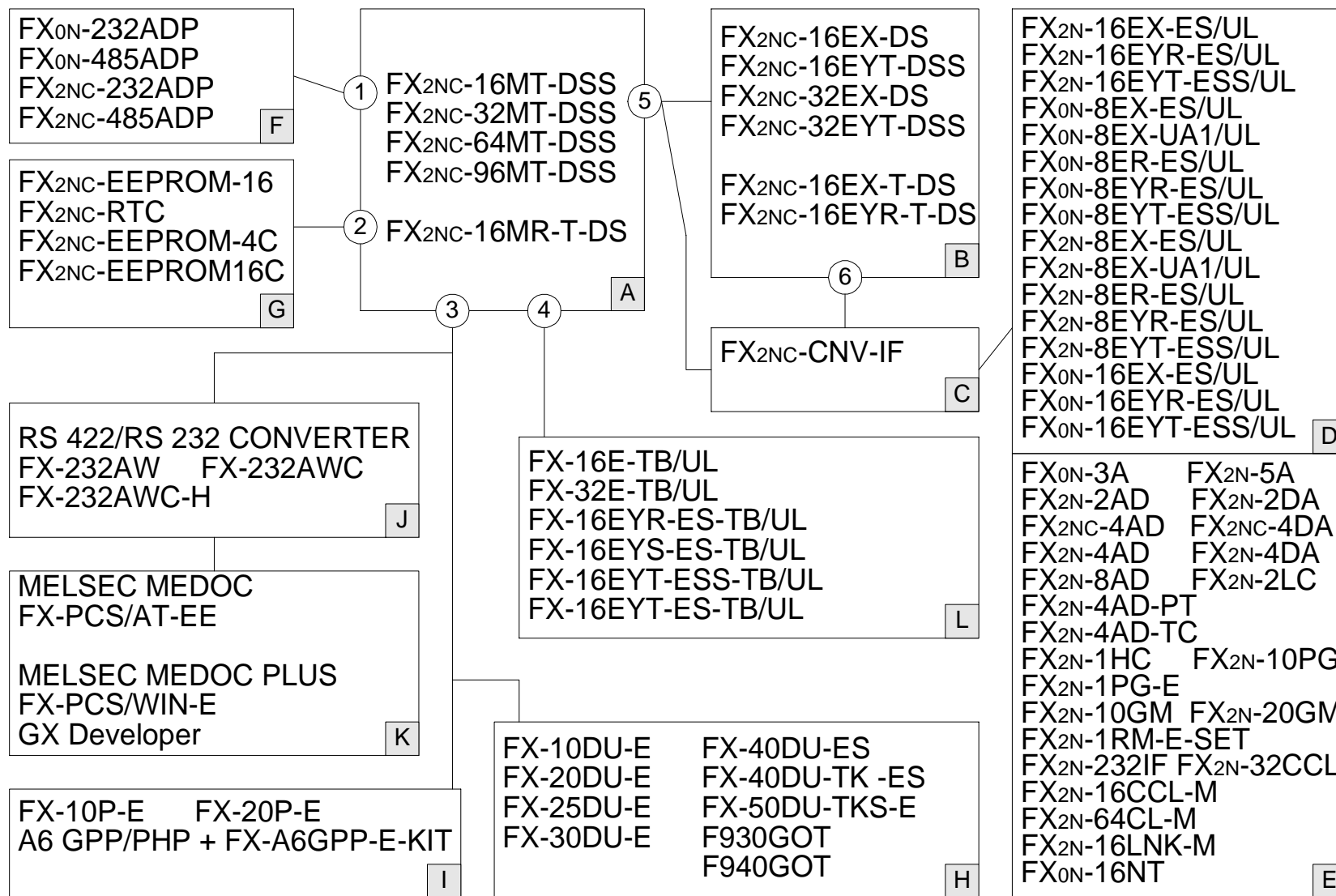

Table 1.8 : Configuration notes

A	MPU-Main unit (Main Processing Unit)
B	Extension block
C	Connector conversion adapter
D	Extension block
E	Special function block
F	Function adapters
G	Memory board (Real time clock)
H	Data access units
I	Dedicated programming
J	Computer interface
K	Computer software
L	Terminal block

①	Left hand side port
②	Memory port
③	Programming port
④	I/O port
⑤	MPU bus port
⑥	Unit bus port

1.5.1 Summary

Connection of FX2NC series extension blocks only

The FX2NC series input extension blocks and FX2NC series output extension blocks can be directly connected to the FX2NC series main unit. These input/output extension blocks can be connected in the desired order. After connection, octal numbers will be assigned to the input/output points of the extension blocks. These octal numbers are regarded as the input/output numbers. The smallest number will be assigned to the input/output point next to the main unit, and then sequentially increased for the subsequent input/output points.

Before connection, calculate the number of connectable input/output points by referring to Sec. 1.5.3, or quickly obtain this number using the table shown in Sec. 1.5.5.

	X020 X037	X040 X057		X060 X077			X100 X117	
X000-X017								
Y000-Y017			Y020 Y037		Y040 Y057	Y060 Y077		Y100 Y117
FX2NC-32MT-DSS	16EX 16 points	16EX 16 points	16EYT 16 points	16EX 16 points	16EYT 16 points	16EYT 16 points	16EX 16 points	16EYT 16 points
X: 16 points Y: 16 points								

Connection of FX₀N and FX₂N series extension blocks and function adapter

To connect an FX₂NC series main unit to FX₀N or FX₂N series extension blocks, be sure to connect an FX₂NC-CNV-IF connector conversion adapter first. Following the adapter, up to 4 blocks can be connected. In addition, one special adapter can be connected to the left side of the base unit. Before connection, calculate the number of connectable input/output points by referring to Sec. 1.5.3.

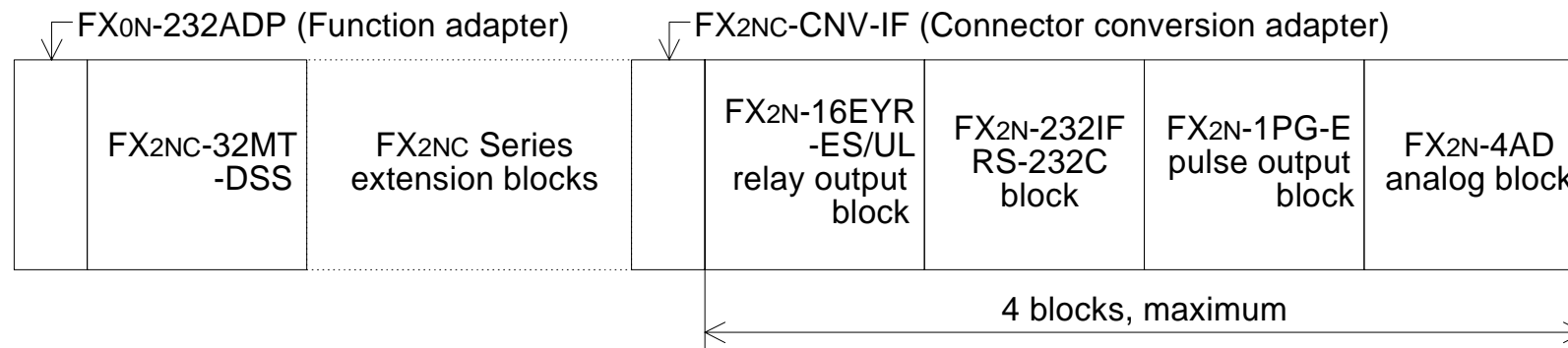

1.5.2 Current consumption and input/output points

The following tables show current consumption and input/output points of various types of FX2NC series main units, extension blocks, and special function blocks.

While referring to Sec. 1.5.3, calculate the total current consumption and input/output values using the following main unit values (values ❶ through ❹), extension block values, and special function block values.

Table 1.9 : Base units

MODEL	❶ CURRENT CAPACITY 5V DC	❷ INPUT X	❸ OUTPUT Y	❹ TOTAL
FX2NC-16MT-DSS FX2NC-16MR-T-DS	600mA	8	8	16
FX2NC-32MT-DSS	560mA	16	16	32
FX2NC-64MT-DSS	480mA	32	32	64
FX2NC-96MT-DSS	400mA	48	48	96

Table 1.10: Extension blocks

MODEL	CURRENT CONSUMPTION 5V DC	INPUT X	OUTPUT Y	TOTAL
FX2NC-16EX-DS	30mA	16	-	16
FX2NC-16EX-T-DS	30mA	16	-	16
FX2NC-16EYT-DSS	50mA	-	16	16
FX2NC-16EYR-T-DS	50mA	-	16	16
FX2NC-32EX-DS	60mA	32	-	32
FX2NC-32EYT-DSS	100mA	-	32	32
FX0N-8ER-ES/UL FX2N-8ER-ES/UL	25mA	4(8)	4(8)	16*1
FX0N-8EX-ES/UL FX2N-8EX-ES/UL	25mA	8	-	8
FX0N-8EX-UA1/UL FX2N-8EX-UA1/UL	25mA	8	-	8
FX0N-8EYR-ES/UL FX2N-8EYR-ES/UL	30mA	-	8	8
FX0N-8EYT-ESS/UL FX2N-8EYT-ESS/UL	30mA	-	8	8
FX0N-16EX-ES/UL	40mA	16	-	16
FX0N-16EYT-ESS/UL	40mA	-	16	16
FX0N-16EYR-ES/UL	40mA	-	16	16
FX2N-16EX-ES/UL	45mA	16	-	16
FX2N-16EYR-ES/UL	40mA	-	16	16
FX2N-16EYT-ESS/UL	180mA	-	16	16

*1: 8 points are used for actual input/output, however, this block should occupy 16 input/output points.

Table 1.11: Special function block Function adapters

MODEL	CURRENT CONSUMPTION 5V DC	INPUT X	OUTPUT Y		TOTAL
			X/Y		
FX0N-3A	30mA	-	8	-	8
FX0N-16NT	20mA	8	-	8	16
FX2N-2AD	20mA	-	8	-	8
FX2N-4AD	30mA	-	8	-	8
FX2NC-4AD	50mA	-	8	-	8
FX2N-8AD	50mA	-	8	-	8
FX2N-4AD-PT	30mA	-	8	-	8
FX2N-4AD-TC	30mA	-	8	-	8
FX2N-5A	70mA	-	8	-	8
FX2N-2DA	30mA	-	8	-	8
FX2N-4DA	30mA	-	8	-	8
FX2NC-4DA	30mA	-	8	-	8
FX2N-8AD	50mA	-	8	-	8
FX2N-2LC	70mA	-	8	-	8
FX2N-1HC	90mA	-	8	-	8
FX2N-1PG-E	55mA	-	8	-	8
FX2N-10PG	120mA	-	8	-	8
FX2N-232IF	40mA	-	8	-	8

MODEL	CURRENT CONSUMPTION 5V DC	INPUT X	OUTPUT		TOTAL
			X/Y	Y	
FX2N-16CCL-M	-	*1	8	*1	8
FX2N-32CCL	130mA	-	8	-	8
FX2N-64CL-M	190mA	*2	8	*2	*2
FX2N-16LNK-M	200mA	*3	*3	*3	*3
FX2N-10GM	-	-	8	-	8
FX2N-20GM	-	-	8	-	8
FX2N-1RM-E-SET *3	-	-	8	-	8
FX0N-232ADP	200mA	-	-	-	-
FX2NC-232ADP	100mA	-	-	-	-
FX0N-485ADP	30mA	-	-	-	-
FX2NC-485ADP	150mA	-	-	-	-
FX-2PIF	290mA	-	-	-	-

*1: Maximum number of I/O points per system Connection is allowed as far as the following condition is satisfied:

$$(\text{Actual number of I/O points of PLC}) + (\text{Number of points occupied by special extension blocks}) + (\text{Number of points occupied by FX2N-16CCL-M: } 8) + (32 \times \text{Number of remote I/O modules}) \leq 256$$

*2: For details, refer to the FX2N-64CL-M user's manual.

*3: Value depends on the switch setting (16, 32, 48, 64, 96 or 128 points).

*4: Maximum of 1 unit can be connected.

1.5.3 Rules

- 1) Add the input/output points of the extension blocks and special functions blocks to the input/output points of the main unit. The total number of input and output points should be no more than 256 points. However, the total number of input points should be 184 points or less, and the total number of output points should also be 184 points or less.
- 2) The FX2NC series main unit supplies control power (5V DC) to the extension blocks and special function blocks. For this reason, the total current consumption of all the blocks connected to the main unit should not exceed the current capacity of the main unit.
- 3) Next to the FX2NC-CNV-IF, up to 4 blocks can be connected. To connect a special function unit, such as the FX-10GM or FX2N-1RM-E-SET, refer to the instruction manual of the corresponding special function block.

Calculation form for system configuration

Enter current consumption values and input/output points of the extension blocks and special function blocks while referring to Sec. 1.5.2, and then calculate the total current value ⑤ and total input and output points ⑥ through ⑨. From the obtained values, judge whether the blocks can be connected.

Table 1.12 : Calculation form

Block	Model	Current consumption	Number of blocks connected	Current consumption × number of blocks	INPUT X		OUTPUT Y	
						X/Y		
FX2NC series input extension block	FX2NC-16EX-DS FX2NC-16EX-T-DS	30 mA	blocks	mA		points		points
	FX2NC-32EX-DS	60 mA	blocks	mA		points		points
FX2NC series output extension block	FX2NC-16EYT-DSS FX2NC-16EYR-T-DS	50 mA	blocks	mA		points		points
	FX2NC-32EYT-DSS	100 mA	blocks	mA		points		points
FX0N/FX2N series extension block (4 blocks, maximum)		mA	blocks	mA	points		points	points
		mA	blocks	mA	points		points	points
		mA	blocks	mA	points		points	points
		mA	blocks	mA	points		points	points
Function adapter		mA	blocks	mA		-		
2-port interface	FX-2PIF	mA	blocks	mA		-		
					⑤ Total current consumption: mA	⑥ Total input points:		points
						⑦ Total output points:		points
						⑧ Total input/output common points:		points
						⑨ Total points:		points

Judgment form

a) 5V DC control current capacity check

$$\begin{array}{|c|} \hline 5V DC current capacity of main unit \\ (value \textcircled{1} \text{ shown in Sec. 1.5.2}): \quad \square \text{ mA} \\ \hline \end{array} \geq \begin{array}{|c|} \hline \text{Total current consumption of all connected blocks} \\ (value \textcircled{5} \text{ written in calculation form}): \quad \square \text{ mA} \\ \hline \end{array}$$

b) Input/output point connection upper limit check

$$\begin{array}{|c|} \hline \text{Input point connection} \\ \text{upper limit : 184 points} \\ \hline \end{array} \geq \left(\begin{array}{|c|} \hline \text{Input points of main unit} \\ (value \textcircled{2} \text{ shown in Sec. 1.5.2}): \\ \square \text{ points} \\ \hline \end{array} + \begin{array}{|c|} \hline \text{Total input points of all} \\ \text{connected blocks (value } \textcircled{6} \\ \text{written in calculation form}):} \\ \square \text{ points} \\ \hline \end{array} = \square \text{ points} \right)$$

$$\begin{array}{|c|} \hline \text{Output point} \\ \text{connection upper limit:} \\ 184 \text{ points} \\ \hline \end{array} \geq \left(\begin{array}{|c|} \hline \text{Output points of main unit} \\ (value \textcircled{3} \text{ shown in Sec. 1.5.2}): \\ \square \text{ points} \\ \hline \end{array} + \begin{array}{|c|} \hline \text{Total output points of all} \\ \text{connected blocks (value } \textcircled{7} \\ \text{written in calculation form):} \\ \square \text{ points} \\ \hline \end{array} = \square \text{ points} \right)$$

$$\begin{array}{|c|} \hline \text{Input/output point} \\ \text{connection upper limit:} \\ 256 \text{ points} \\ \hline \end{array} \geq \left(\begin{array}{|c|} \hline \text{Input/output points of main unit} \\ (value \textcircled{4} \text{ shown in Sec. 1.5.2}): \\ \square \text{ points} \\ \hline \end{array} + \begin{array}{|c|} \hline \text{Total input/output points of all} \\ \text{connected blocks (value } \textcircled{9} \\ \text{written in calculation form):} \\ \square \text{ points} \\ \hline \end{array} = \square \text{ points} \right)$$

If all the above conditions are met, the extension and special function blocks can be connected to the base block.

If one of the above conditions is not met, reduce the number of input/output points or number of blocks, or change the types of blocks to be connected.

1.5.4 System configuration example

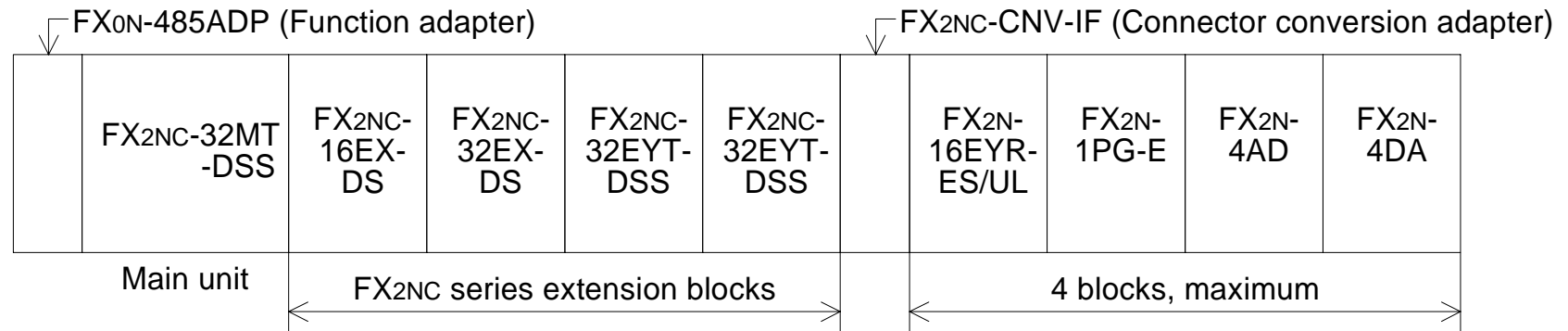

Table 1.13 : Calculation (Example)

Block	Model	Current consumption	Number of blocks connected	Current consumption × number of blocks	INPUT X		OUTPUT Y		
					X	X/Y		Y	
FX2NC series input extension block	FX2NC-16EX-DS FX2NC-16EX-T-DS	30 mA	1 blocks	30 mA	16 points			points	
	FX2NC-32EX-DS	60 mA	1 blocks	60 mA	32 points			points	
FX2NC series output extension block	FX2NC-16EYT-DSS FX2NC-16EYR-T-DS	50 mA	0 blocks	0 mA				points	
	FX2NC-32EYT-DSS	100 mA	2 blocks	200 mA				64 points	
FX0N/FX2N series extension block (4 blocks, maximum)	FX2N-16EYR-ES/UL	40 mA	1 blocks	40 mA	points		points	16 points	
	FX2N-1PG-E	55 mA	1 blocks	55 mA	points		8 points	points	
	FX2N-4AD	30 mA	1 blocks	30 mA	points		8 points	points	
	FX2N-4DA	30 mA	1 blocks	30 mA	points		8 points	points	
Function adapter	FX0N-485ADP	30 mA	1 blocks	30 mA				-	
2-port interface	FX-2PIF	mA	0 blocks	0 mA				-	
					⑤ Total current consumption: 475 mA	⑥ Total input points: 48 points		⑦ Total output points : 80 points	
						⑧ Total input/output common points: 24 points		⑨ Total points: 152 points	

Judgment (Example)

a) 5V DC control current capacity check

5V DC current capacity of main unit (value ❶ shown in Sec. 1.5.2): 560 mA	≥	Total current consumption of all connected blocks (value ❺ written in calculation form): 475 mA	OK
--	---	--	----

b) Input/output point connection upper limit check

Input point connection upper limit : 184 points	≥	Input points of main unit (value ❷ shown in Sec. 1.5.2): 16 points	+	Total input points of all connected blocks (value ❻ written in calculation form): 48 points	=	64 points	OK
Output point connection upper limit: 184 points	≥	Output points of main unit (value ❸ shown in Sec. 1.5.2): 16 points	+	Total output points of all connected blocks (value ❼ written in calculation form): 80 points	=	96 points	OK
Input/output point connection upper limit: 256 points	≥	Input/output points of main unit (value ❹ shown in Sec. 1.5.2): 32 points	+	Total input/output points of all connected blocks (value ❽ written in calculation form): 152 points	=	184 points	OK

Calculation result:

The 5V DC power total current consumption value and total input/output points are in the specified ranges, therefore the above system configuration is possible.

1.5.5 Quick judgment

To connect FX₂NC series extension blocks only, use the following tables to quickly obtain the connectable input/output points.

Example of quick judgment:

- If 96 input points are connected to an FX₂NC-32MT-DSS main unit, up to 112 output points can be connected.
- If the number of output points are determined first, select the same number or a slightly larger number from the output points (Y) area (marked with *1). In this case, note that you cannot increase the corresponding number of input points shown above even if the determined number of output points is slightly smaller than the number shown in the table. However, if the same number of output points are listed twice, you can select the larger number of input points.

Table 1.14: FX₂NC-16M main unit (input: 8 points / output: 8 points)

Input points of FX ₂ NC series input extension block (X)	0	16	32	48	64	80	96	112	128	144	160	176	
Output points of FX ₂ NC series output extension block (Y)	176	176	160	160	144	144	128	112	112	96	80	64	←*1
Total points including those of main unit	192	208	208	224	224	240	240	240	256	256	256	256	

Table 1.15: FX2NC-32M main unit (input: 16 points / output: 16 points)

Input points of FX2NC series input extension block (X)	0	16	32	48	64	80	96	112	128	144	160
Output points of FX2NC series output extension block (Y)	168	160	160	144	128	128	112	112	96	80	64
Total points including those of main unit	200	208	224	224	224	240	240	256	256	256	256

←*1
↑ Example of quick judgment

Table 1.16: FX2NC-64M main unit (input: 32 points / output: 32 points)

Input points of FX2NC series input extension block (X)	0	16	32	48	64	80	96	112	128	144
Output points of FX2NC series output extension block (Y)	144	144	128	112	112	96	96	80	64	48
Total points including those of main unit	208	224	224	224	240	240	256	256	256	256

←*1

Table 1.17: FX2NC-96M main unit (input: 48 points / output: 48 points)

Input points of FX2NC series input extension block (X)	0	16	32	48	64	80	96	112	128
Output points of FX2NC series output extension block (Y)	128	112	96	96	80	80	64	48	32
Total points including those of main unit	224	224	224	240	240	256	256	256	256

←*1

1	INTRODUCTION
2	TERMINAL LAYOUTS
3	INSTALLATION NOTES
4	POWER SUPPLY
5	INPUTS
6	OUTPUTS
7	DIAGNOSTICS

2. Terminal layouts

The following selection of terminal layouts are taken from the FX2NC product range.

Note: All layouts are diagrammatic and are only intended to aid the creation of wiring diagrams.

2.1 Main units

FX2NC-16MT-DSS

IN		OUT	
X0	•	Y0	•
X1	•	Y1	•
X2	•	Y2	•
X3	•	Y3	•
X4	•	Y4	•
X5	•	Y5	•
X6	•	Y6	•
X7	•	Y7	•
COM0	COM0	+V0	+V0
•	•	•	•

FX2NC-16MR-T-DS

IN	OUT
X0	Y0
X1	Y1
X2	Y2
X3	Y3
COM	COM1
•	•
X4	Y4
X5	Y5
X6	Y6
X7	Y7
COM	COM2

FX2NC-32MT-DSS

IN		OUT	
X0	X10	Y0	Y10
X1	X11	Y1	Y11
X2	X12	Y2	Y12
X3	X13	Y3	Y13
X4	X14	Y4	Y14
X5	X15	Y5	Y15
X6	X16	Y6	Y16
X7	X17	Y7	Y17
COM0	COM0	+V0	+V0
•	•	•	•

FX2NC-64MT-DSS

IN		OUT		IN		OUT	
X0	X10	Y0	Y10	X20	X30	Y20	Y30
X1	X11	Y1	Y11	X21	X31	Y21	Y31
X2	X12	Y2	Y12	X22	X32	Y22	Y32
X3	X13	Y3	Y13	X23	X33	Y23	Y33
X4	X14	Y4	Y14	X24	X34	Y24	Y34
X5	X15	Y5	Y15	X25	X35	Y25	Y35
X6	X16	Y6	Y16	X26	X36	Y26	Y36
X7	X17	Y7	Y17	X27	X37	Y27	Y37
COM0	COM0	+V0	+V0	COM1	COM1	+V1	+V1
•	•	•	•	•	•	•	•

FX2NC-96MT-DSS

IN		OUT		IN		OUT		IN		OUT	
X0	X10	Y0	Y10	X20	X30	Y20	Y30	X40	X50	Y40	Y50
X1	X11	Y1	Y11	X21	X31	Y21	Y31	X41	X51	Y41	Y51
X2	X12	Y2	Y12	X22	X32	Y22	Y32	X42	X52	Y42	Y52
X3	X13	Y3	Y13	X23	X33	Y23	Y33	X43	X53	Y43	Y53
X4	X14	Y4	Y14	X24	X34	Y24	Y34	X44	X54	Y44	Y54
X5	X15	Y5	Y15	X25	X35	Y25	Y35	X45	X55	Y45	Y55
X6	X16	Y6	Y16	X26	X36	Y26	Y36	X46	X56	Y46	Y56
X7	X17	Y7	Y17	X27	X37	Y27	Y37	X47	X57	Y47	Y57
COM0	COM0	+V0	+V0	COM1	COM1	+V1	+V1	COM2	COM2	+V2	+V2
•	•	•	•	•	•	•	•	•	•	•	•

2.2 FX2NC Extension blocks

FX2NC-16EX-DS

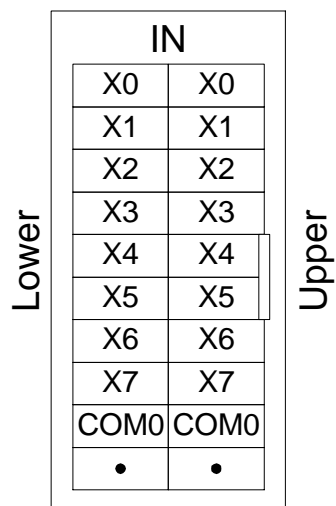

FX2NC-32EX-DS

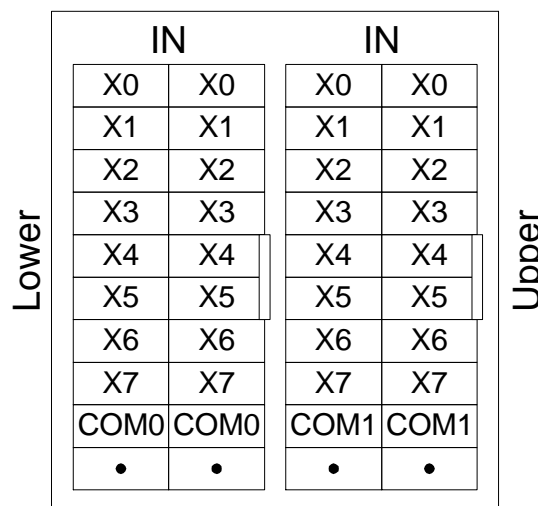

FX2NC-16EX-T-DS

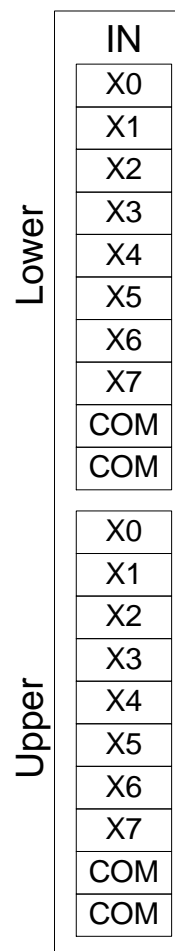

FX2NC-16EYR-T-DS

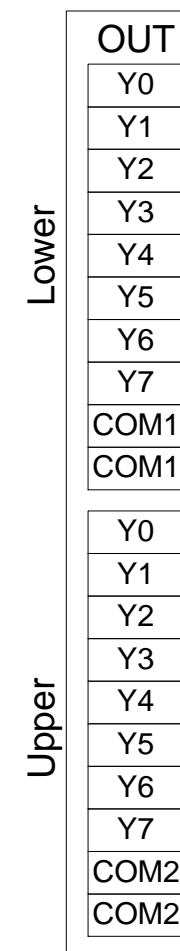

FX2NC-16EYT-DSS

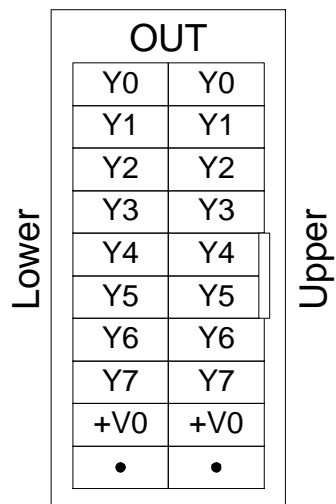

FX2NC-32EYT-DSS

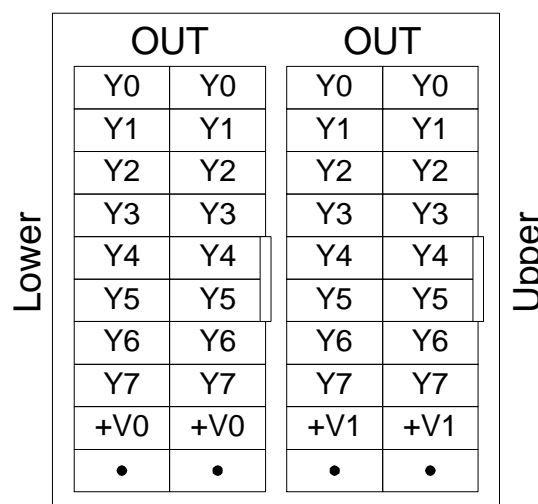

2.3 FX2N and FX0N Extension blocks

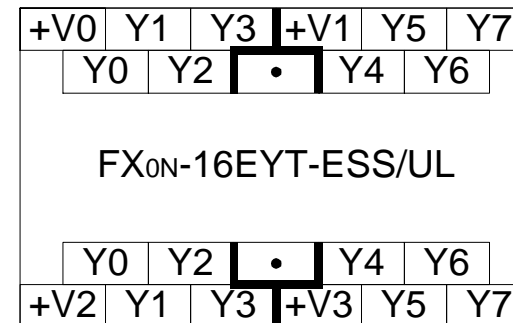
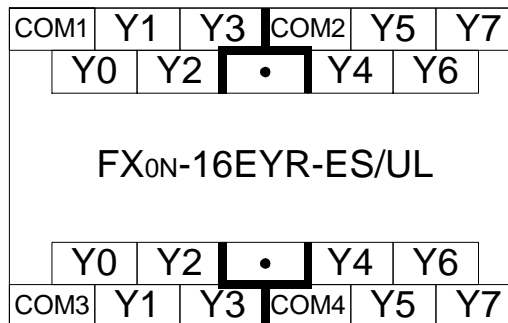
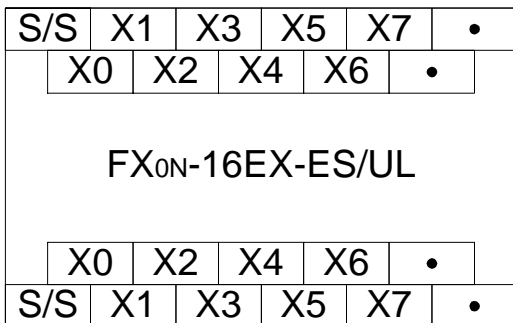
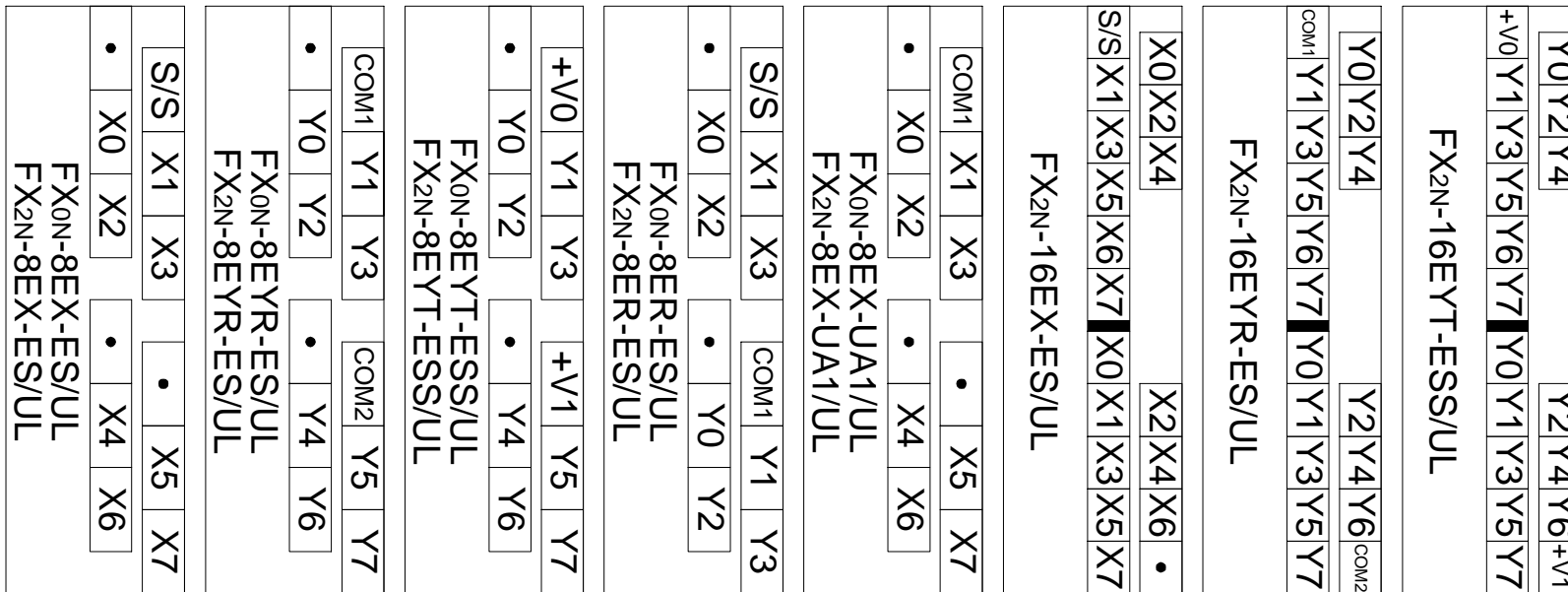

1	INTRODUCTION
2	TERMINAL LAYOUTS
3	INSTALLATION NOTES
4	POWER SUPPLY
5	INPUTS
6	OUTPUTS
7	DIAGNOSTICS

3. Installation notes

The installation of FX2NC products has been designed to be safe and easy. When the products associated with this manual are used as a system or individually, they must be installed in a suitable enclosure. The enclosure should be selected and installed in accordance to the local and national standards.

3.1 Product outline

Figure 3.1: Features of the FX2NC PLC

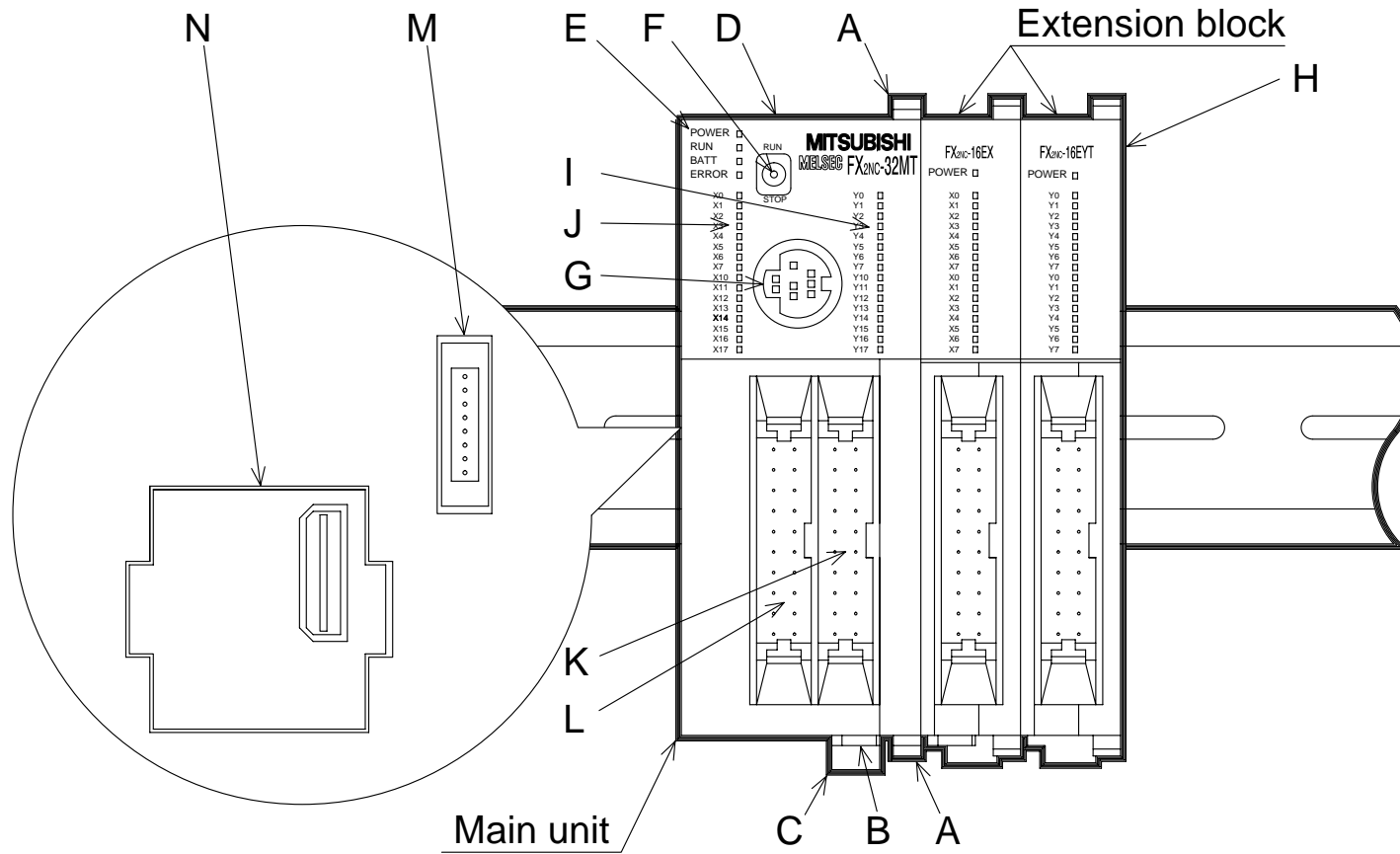

Table 3.1 : Feature table

A	Slide lock for extension I/O block
B	Power supply connector (Uses the 24V DC)
C	Din rail clip
D	Backup battery
E	Status indicators (POWER, RUN, BATT, ERROR)
F	Run / Stop switch
G	Programming port
H	Extension port
I	Output indicators
J	Input indicators
K	Output connector or Output terminal
L	Input connector or Input terminal
M	Function adapter port
N	Memory board / Real time clock board, port

3.2 FX2NC RUN/STOP Control

RUN or STOP of the FX2NC can be controlled by:

- ❶ The RUN/STOP switch mounted next to the programming port.
- ❷ A standard input (X0 to X17; X0 to x7 for FX2NC-16M★ units) defined by the system parameters.
- ❸ Remotely from a personal computer or other programming peripheral.



Note: The FX2NC RUN/STOP switch ❶ works in parallel with the RUN-input terminal ❷. Please refer to table 3.2.

During remote operation the FX2NC RUN/STOP status is determined by the most recently operated control.

E.g. If the RUN/STOP switch is in RUN and a remote STOP is made from a personal computer the RUN/STOP switch must be switched to STOP then back to RUN to switch the MPU back to RUN mode.

Table 3.2 : RUN/STOP selection

① RUN/STOP SWITCH	② RUN INPUT TERMINAL	FX2NC MPU STATUS
✓	✓	RUN
✓	✗	RUN
✗	✗	STOP
✗	✓	RUN

Figure 3.2:

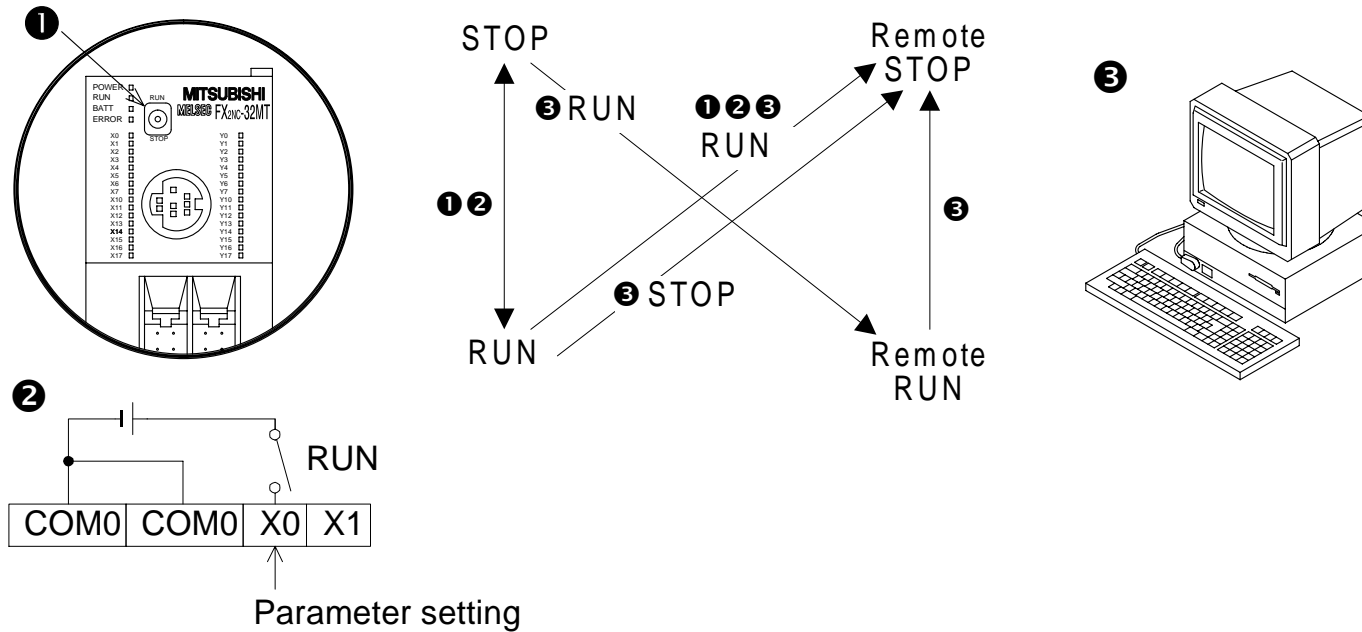

3.3 General specifications

Table 3.3: General Specifications

Item	Description
Operating Temperature	0 to 55 °C (32 to 131 °F)
Storage Temperature	-20 to 70 °C (-4 to 158 °F)
Operating Humidity	35 to 85% Relative Humidity, No condensation
storage Humidity	35 to 90% Relative Humidity, No condensation
Vibration Resistance - Direct Mounting	Conforms to JIS C0040; 10 - 57 Hz: 0.075 mm Half Amplitude 57 - 150 Hz: 9.8 m/s ² Acceleration Sweep Count for X, Y, Z: 10 times (80 min in each direction)
Vibration Resistance - DIN rail Mounting	Conforms to JIS C0040; 10 - 57 Hz: 0.035 mm Half Amplitude 57 - 150 Hz: 4.9 m/s ² Acceleration Sweep Count for X, Y, Z: 10 times (80 min in each direction)
Shock Resistance	Conforms to JIS C0041: 147m/s ² Acceleration, Action Time: 11 ms 3 times in each direction X, Y, and Z
Noise Immunity	1000 Vp-p, 1microsecond, 30 - 100 Hz, tested by noise simulator
Dielectric Withstand Voltage	500 V AC > 1 min, tested between all points, terminals and ground
Insulation Resistance	5 MΩ > at 500 V DC, tested between all points, terminals and ground
Ground	Class D (100 Ω or less)

3.4 PLC mounting arrangements

To prevent a rise in temperature, mount the units to walls. Never mount them to the floor or ceiling of an enclosure.

Figure 3.3 Single row arrangement

Figure 3.4 Double row arrangement using extension cable FX0N-65EC (650mm (25.59 inches); supplied separately).

Figure 3.3 :

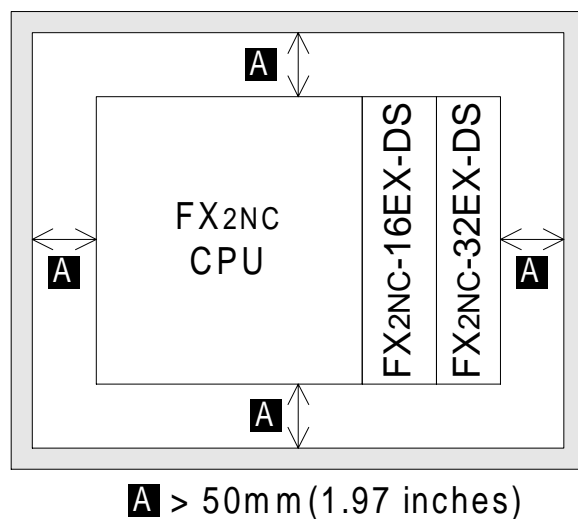
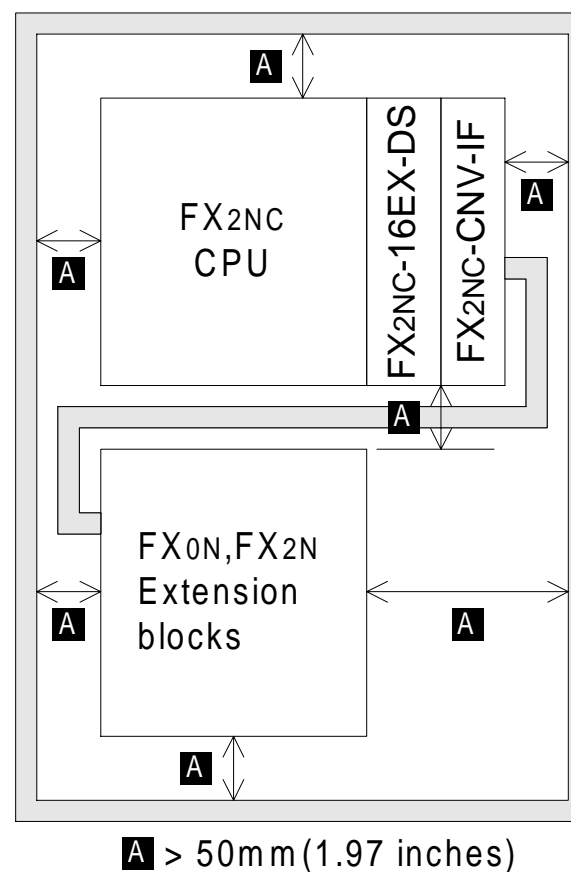

Figure 3.4 :





Caution

- Units should not be installed in areas subject to the following conditions: excessive or conductive dust, corrosive gas (salt air, Cl₂, H₂S, SO₂, NO₂, etc.) or flammable gas, moisture or rain, excessive heat, regular impact shocks or excessive vibration.
- Take special care not to allow debris to fall inside the unit during installation e.g. cut wires, shavings etc. Once installation is complete remove the protective paper band: to prevent overheating.

3.5 Connection of extension blocks to main unit

- 1) Remove the port cover from the right side of the main unit.
- 2) Push up the slide lock of the main unit, and then connect an extension block.
- 3) Slide down the lock to secure the extension block.
Connect other extension blocks in the same way.

Figure 3.5 :

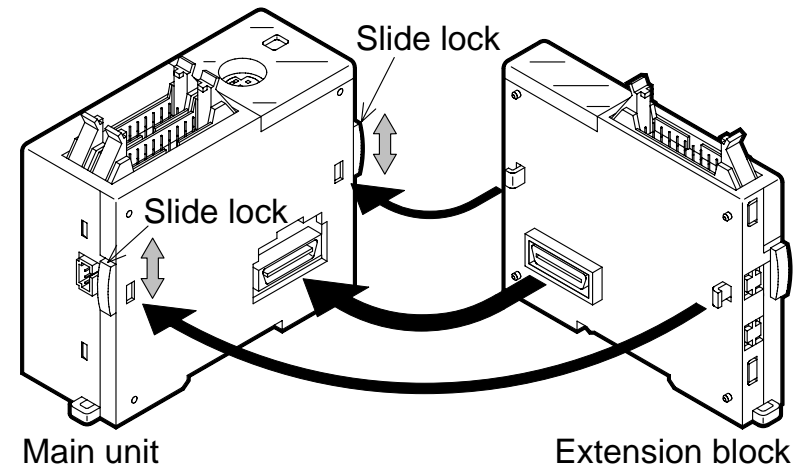

3.6 DIN rail mounting

DIN 46277 rail (35 mm, 1.4 inches) can be directly installed on the FX2NC series programmable controller. (Do not use any screws for this installation.) To remove the main body, slightly pull down the DIN rail mounting clip. Slide the clip further, and the rail will be locked with the clip left open.

To connect the FX2N series extension blocks, slide the DIN rail mounting clip in the arrow direction as shown to the right.

Figure 3.6 :

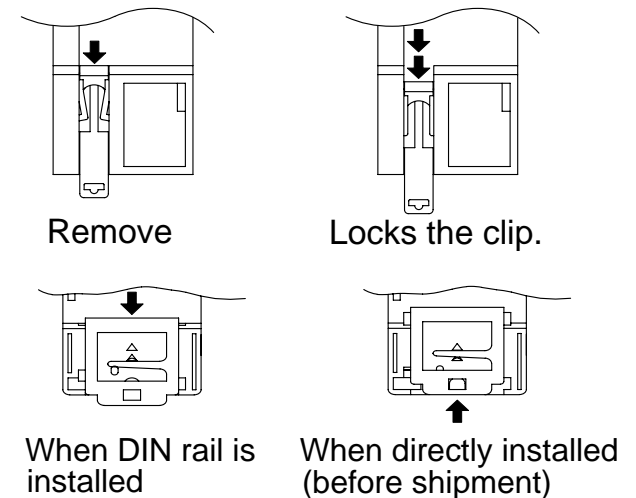

3.7 Direct mounting

Figure 3.7 :Group1

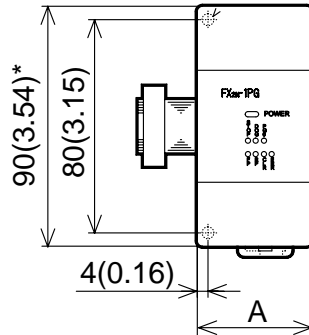

*: FX2N-1RM is 111(4.37)

∅ = 4.5mm (0.18)

UNITS: mm (inches)

Table 3.4 :

MODEL	A	MODEL	A	MODEL	A
FX2N-4DA	55 (2.16)	FX2N-2DA	43 (1.69)	FX0N-8E□	43 (1.69)
FX2N-4AD		FX2N-2AD		FX2N-8E□	
FX2N-4AD-PT		FX2N-32CCL		FX2N-64CL-M	
FX2N-4AD-TC		FX2N-16LNK-M		FX2N-10PG	75(2.95)
FX2N-5A		FX0N-3A		FX2N-8AD	
FX2N-1HC		FX0N-16NT		FX2N-16CCL-M	85(3.35)
FX2N-232IF		FX2N-1PG-E			
FX2N-1RM		FX0N-232ADP			
FX2N-2LC		FX0N-485ADP			

Figure 3.8: Group 2

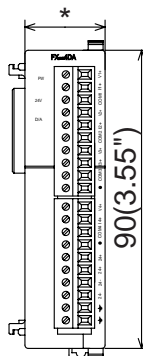
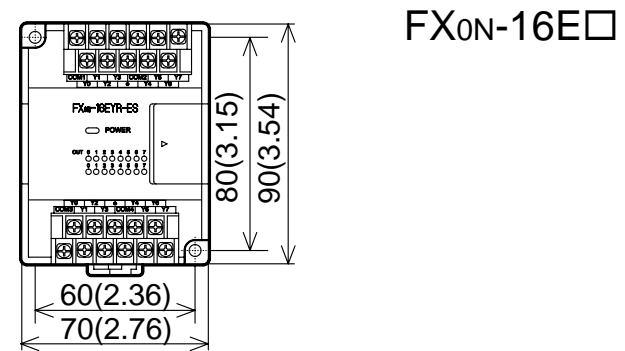
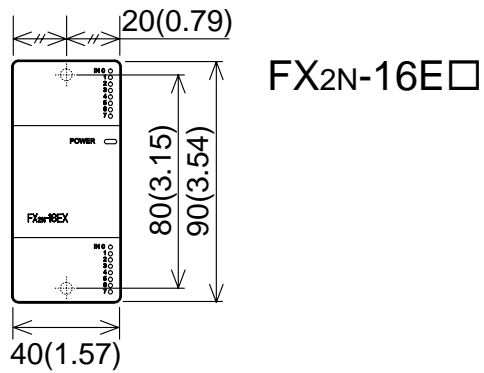

- *: FX2NC-4DA is 24.2 (0.96).
- *: FX2NC-4AD is 20.2 (0.8).

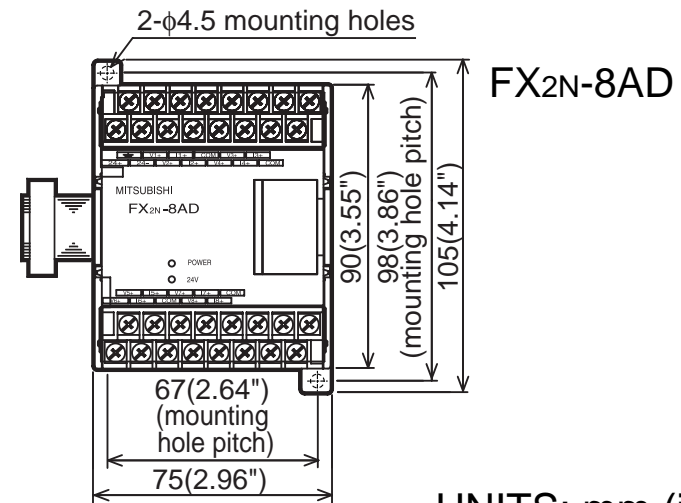

UNITS: mm (inches)

Figure 3.9:Side view

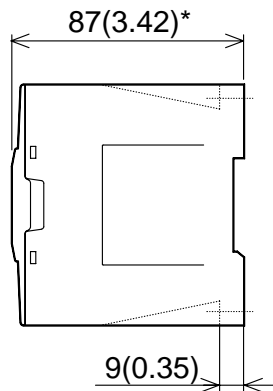

* : FX₂N-232IF is 85 (3.35)
 FX₂N-1RM is 97(3.82)
 FX₀N-232ADP is 68(2.68)
 FX₂N-8AD is 75(2.95)

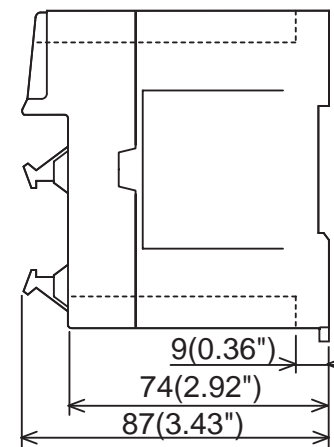

FX₂N-10PG

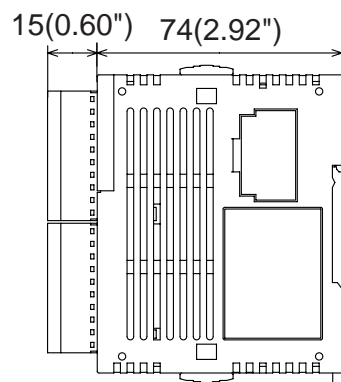

FX₂NC-4DA
 FX₂NC-4AD

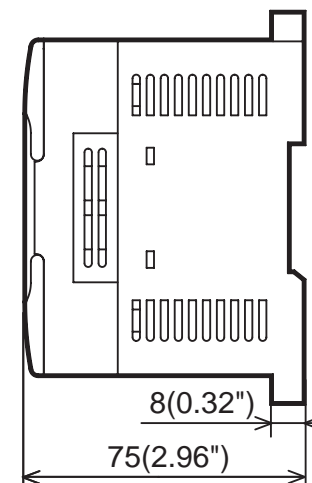

FX₂N-8AD

UNITS: mm (inches)

3.8 Extension cable installation

To connect extension blocks next to the FX₂NC-CNV-IF block, use the FX₀N-30EC or FX₀N-65EC extension cable. Note that only one extension cable can be used for one system. In addition, to connect extension blocks, use the FX₂N-CNV-BC connector conversion adapter as shown below.

Figure 3.10:

Connection example 1

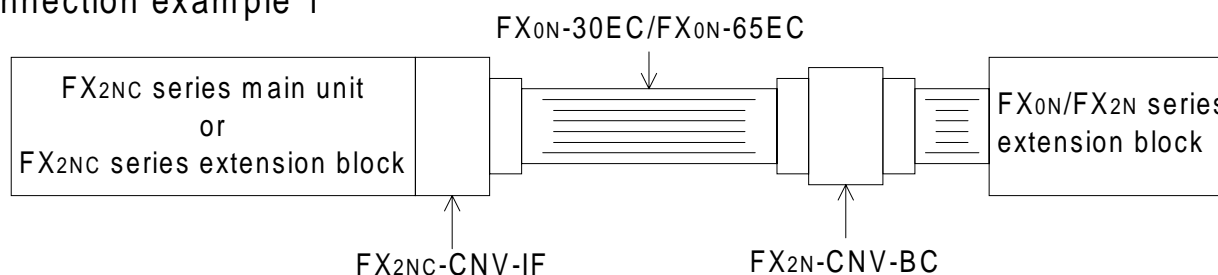
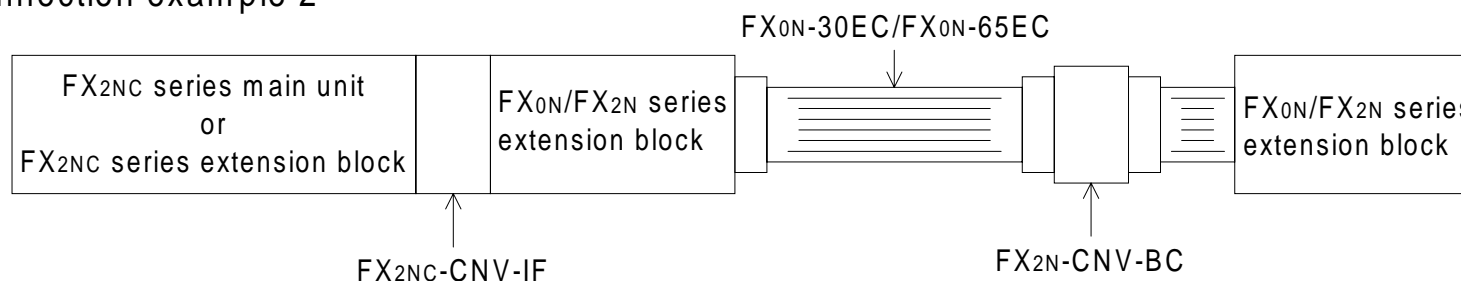

Figure 3.11:

Connection example 2



3.9 General notes



Always ensure that mounted units and blocks are kept as far as possible from high-voltage cables, high-voltage equipment and power equipment.

3.10 Memory Board installation

Figure 3.12:Installation

- 1) Turn off the power to the programmable controller.
- 2) Remove the cover from the memory board installation section.
- 3) Connect the memory board while carefully inserting the pins.

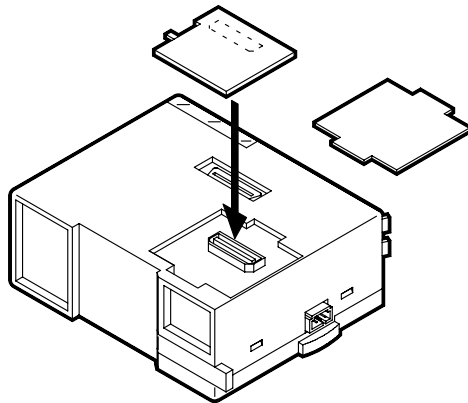
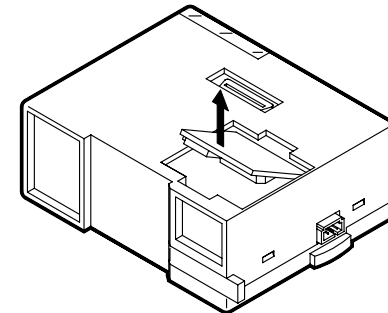

Figure 3.13:Removal

- 1) Turn off the power to the programmable controller.
- 2) Remove the cover from the memory board installation section.
- 3) Slowly pull up the lower section of the memory board, and completely remove the board.



- Before removing or installing the memory board, be sure to turn off the power.
- If the memory board is removed or installed with the power on, it may be damaged.
- During memory board removal or installation, be careful not to directly touch any electronic parts.

3.11 Wiring techniques

The wiring of FX₂NC products has been designed to be safe and easy. If during the installation of these products or associated products concern is felt, please contact a professional electrician who is trained to the local and national standards applicable to the installation site.



Wiring cautions

- Do not run input signals in the same multicore cable as output signals or allow them to share the same wire.
- Do not lay I/O signal cables next to power cables or allow them to share the same trunking duct. Low voltage cables should be reliably separated or insulated with regard to high voltage cabling.
- Where I/O signal lines are used over an extended distance consideration for voltage drop and noise interference should be made.

3.12 Termination of connector style I/O

I/O connectors should be 20-pin type and conform to MIL C 83503 of Military Standard. This type of connector is also used for FX2c series programmable controllers.



The output connectors of the main unit and the connector-type 16-point output extension blocks are 16-point common type (8-point common type for the FX2NC-16MT). These output connectors have two +V0 to +V2 pins that are connected to each other inside the programmable controller. To connect the line to an external unit, shortcircuit these two pins at the external circuit so that the load of each pin can be reduced.

3.13 Termination of Terminal style I/O



Observe the following cautions, and properly wire the I/O cables of the terminal style FX2NC PLC.

If you do not observe the following cautions, electrical shock, shortcircuit, disconnection and damages in the unit may be caused.

- Make sure that the end of each cable is treated into the size shown in Fig. 3.14.
- Twist the end of each stranded cable so that barbed wires are not present.
- Never solder the end of any cables.
- Never connect cables whose size is not allowed. Make sure that the number of connected cables is not more than a specified number.
- Fix cables so that the stress is not directly applied on the terminal block and the cable connection area.



The output connectors of FX₂NC-16MR-T-DS are 4-point common type.
 The output connectors of FX₂NC -16EYR-T-DS are 8-point common type.
 The output terminal block in the FX₂NC-16EYR-T-DS has two COM1 or COM2 pins that are connected to each other inside the main unit.
 To connect the line to an external unit, shortcircuit these two pins at the external circuit so that the load applied on each pin can be reduced.

Table 3.5 :Applicable cables

Model	Cable size (stranded/single)	Tightening torque	Terminal
One cable	0.3 to 0.5 mm ² (AWG 22 to 20)	0.22 to 0.25 N·m	<ul style="list-style-type: none"> • Stranded cable: Rip off sheath, twist core wires, then connect cable as it is. • Single cable: Rip off sheath, then connect cable as it is.
Two cables	0.3 mm ² (AWG 22) × 2 cables		
Ferrules, with plastic insulating sleeve	0.3 to 0.5 mm ² (AWG 22 to 20) (Refer to outline drawing of ferrule shown later.)		<ul style="list-style-type: none"> • Ferrule with insulating sleeve (recommended) AI 0, 5-8WH (manufactured by PHOENIX CONTACT) • Caulking tool CRIMPFOX UD6(manufactured by PHOENIX CONTACT)

Figure 3.14: Cable end treatment size

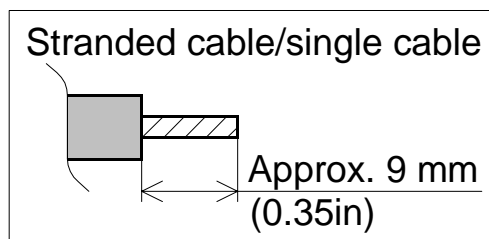

Treat the end of a cable in accordance with the hardware warning shown in the previous page.

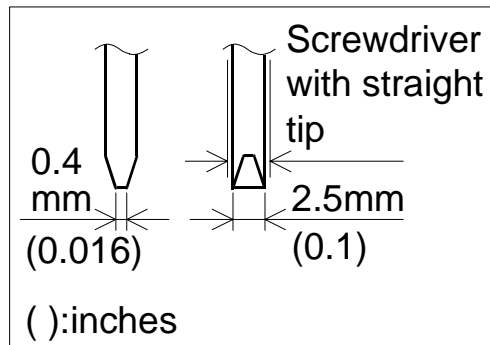
Figure 3.15: Specifications of terminal block tightening screwdriver

Use a small commercial screwdriver of the size shown on the left. Make sure that the tip is straight, and is not broadened.

Recommended dedicated screwdriver:
Model SZS 0, 4 × 2, 5 (manufactured by PHOENIX CONTACT)

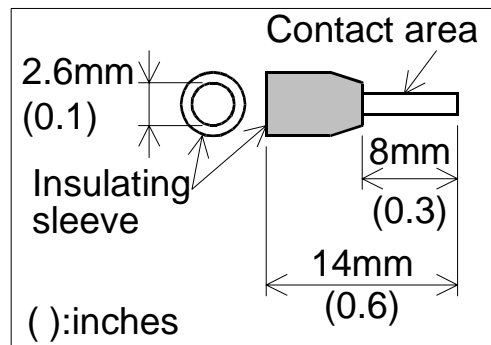
Figure 3.16 : Outline drawing of ferrule with insulating sleeve (manufactured by PHOENIX CONTACT)

- Recommended ferrule: Model AI 0, 5-8WH
- Caulking tool: CRIMPFOX UD6

A cable may not be smoothly inserted into the insulating sleeve if the sheath of the cable is thick. Select a proper cable while referring to the outline drawing.

Point of contact of PHOENIX CONTACT:

Web page <http://www.phoenixcontact.com/>

3.14 Termination of screw terminals

Cables terminating at a screw terminal of an FX_{2N} or FX_{0N} product should be fitted with insulated crimp terminals, see example shown. Terminal screws should be tightened to between 0.5 to 0.8 N·m. Screw terminals must be secured to prevent a loose connection from causing a malfunction.

Figure 3.17:

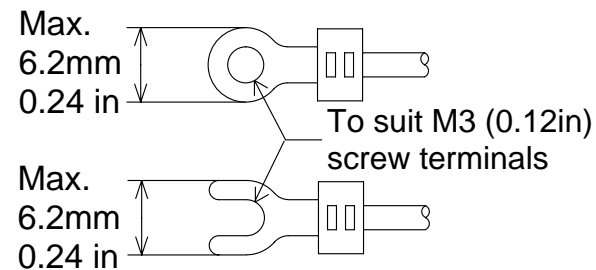

3.15 Termination of connector style I/O cables

Standard, pre-terminated cables are available from Mitsubishi in 1.5, 3 and 5 meter (4.9, 9.8 and 16.4 ft) lengths. However, users are encouraged to make their own cables to the lengths they require. The following table identifies connectors and cable requirements;

Figure 3.18:

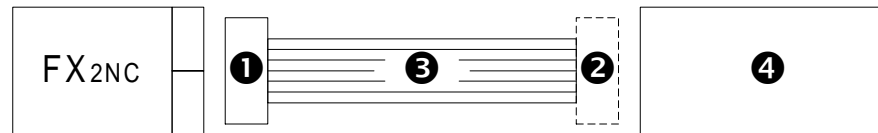

Table 3.6 :

() : ft

MODEL	LENGTH	①	②	③	④
FX-16E-500CAB-S	5m (16.4)	20 Pin connector	No connector	Single wire	Input switch or Loads
FX-16E-150CAB	1.5m (4.9)	20 Pin connector	20 Pin connector	Flat cables	TERMINAL BLOCK ·FX-16E-TB/UL ·FX-32E-TB/UL ·FX-16EYR-ES-TB/UL ·FX-16EYT-ESS-TB/UL ·FX-16EYT-ES-TB/UL ·FX-16EYS-TB/UL
FX-16E-300CAB	3m (9.8)				
FX-16E-500CAB	5m (16.4)				
FX-16E-150CAB-R	1.5m (4.9)	20 Pin connector	20 Pin connector	Round cables	
FX-16E-300CAB-R	3m (9.8)				
FX-16E-500CAB-R	5m (16.4)				

MEMO

1	INTRODUCTION
2	TERMINAL LAYOUTS
3	INSTALLATION NOTES
4	POWER SUPPLY
5	INPUTS
6	OUTPUTS
7	DIAGNOSTICS

4. Power supply

Table 4.1 : Power requirements

	FX2NC-16MR-T-DS	FX2NC-16MT-DSS	FX2NC-32MT-DSS	FX2NC-64MT-DSS	FX2NC-96MT-DSS
Power supply	24V DC +20%, -15% Ripple Voltage (p-p) 5% or less				
Max. allowable momentary power failure period	5ms (5ms > PLC = RUN, 5ms < PLC = STOP)				
Fuse (size) rating	125V 2.5A 250V 3.15A (3A) 5φ×20mm (0.2×0.79 inches)				
In-rush current	30A or less 0.5ms/24V DC				
Power consumption *1	6W	6W	8W	11W	14W

*1 Includes input current (7 or 5 mA per point).

Table 4.2 : Power consumption of FX2nc extension blocks

When connecting extension blocks, add the values shown below to the power consumption value of the main unit.

Type	Model	Power consumption
Input extension	FX2NC-16EX-DS, FX2NC-16EX-T-DS	2.2W *2
	FX2NC-32EX-DS	4.2W *2
Output extension	FX2NC-16EYT-DSS	0.35W
	FX2NC-16EYR-T-DS	2.2W
	FX2NC-32EYT-DSS	0.7W
Special extension	See sec. Table 1.4	

*2 Includes input current (5 mA per point).



For the 24V DC power source of FX or FX_{2N} series programmable controllers, the correction value should be written in data register D8008; a special data register that sets the power failure detection period. However, for FX_{2NC} series programmable controllers, it is not necessary to write the correction value.

The data stored in D8008 register will be automatically corrected by the system program. Do not modify D8008.

Figure 4.1 : Connection of power supply cables

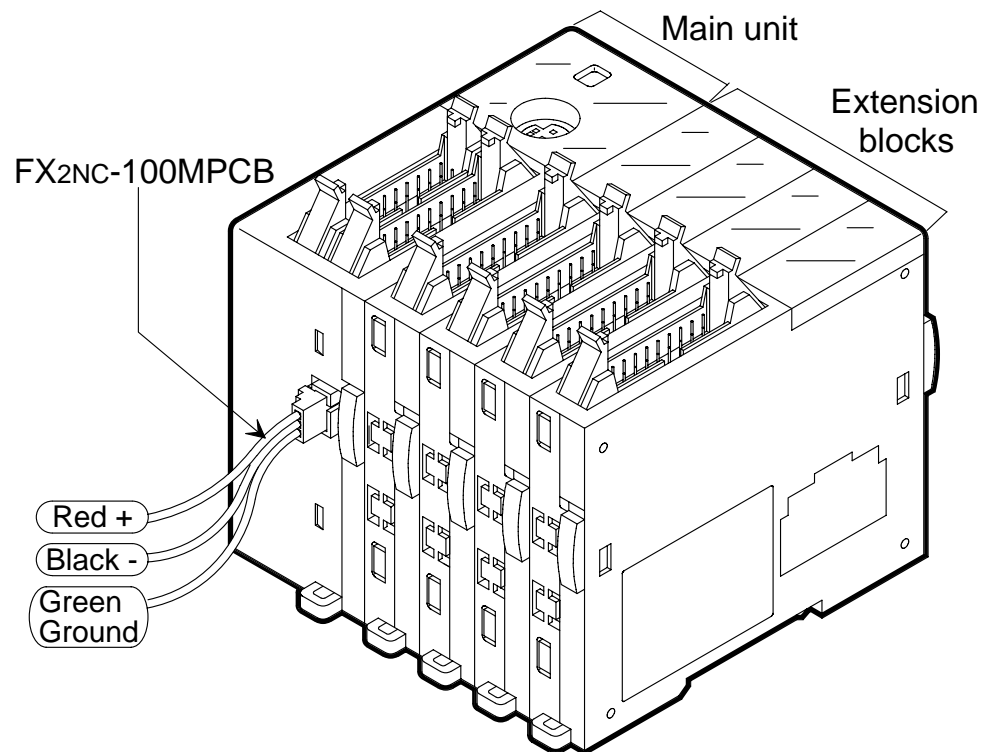

Terminal layout of power supply connector

Main unit

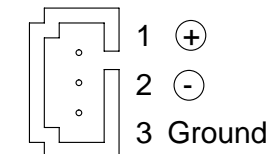
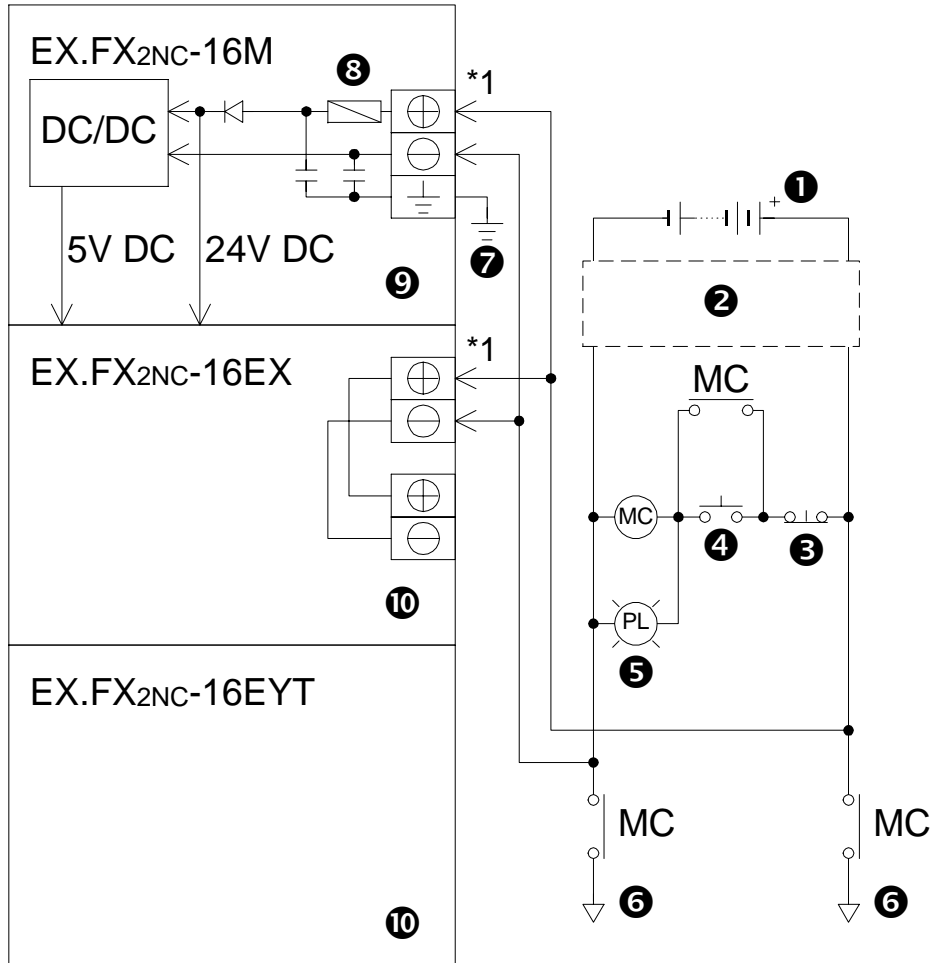

Figure 4.2 : EX.wiring



①	Power supply 24V DC +20% -15% Ripple voltage (p-p) 5% or less
②	Circuit protector or Fuse
③	Emergency stop
④	Power supply switch
⑤	Power ON pilot indicator
⑥	Power supply for loads
⑦	Grounding resistor 100Ω or less (class D)
⑧	Fuse
⑨	Main unit
⑩	Extension blocks

*1 It is recommended to use the same power source to power the main unit, input extension blocks and special function blocks. If two sources are required, follow the below guidelines:

- Supply power to the input extension blocks and special function blocks before or at the same time the main unit is powered.
- The power supplies may be cut the same time after ensuring system safety.

4.1 Power supply cautions



As shown in the following figure, supply 24V DC to the main unit, special function blocks, and data access unit from the same power source.

Figure 4.3 : Use of same power source

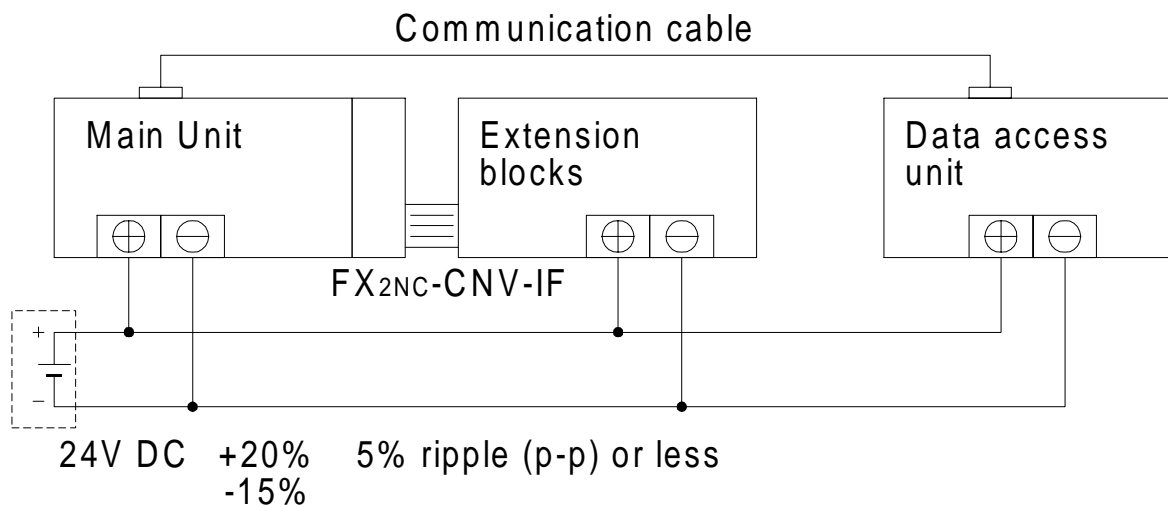



If the power has to be supplied from two power sources due to low capacity of the DC power supply unit, etc., be sure to connect the minus lines of the two power supply units.

Figure 4.4: Connection of minus lines

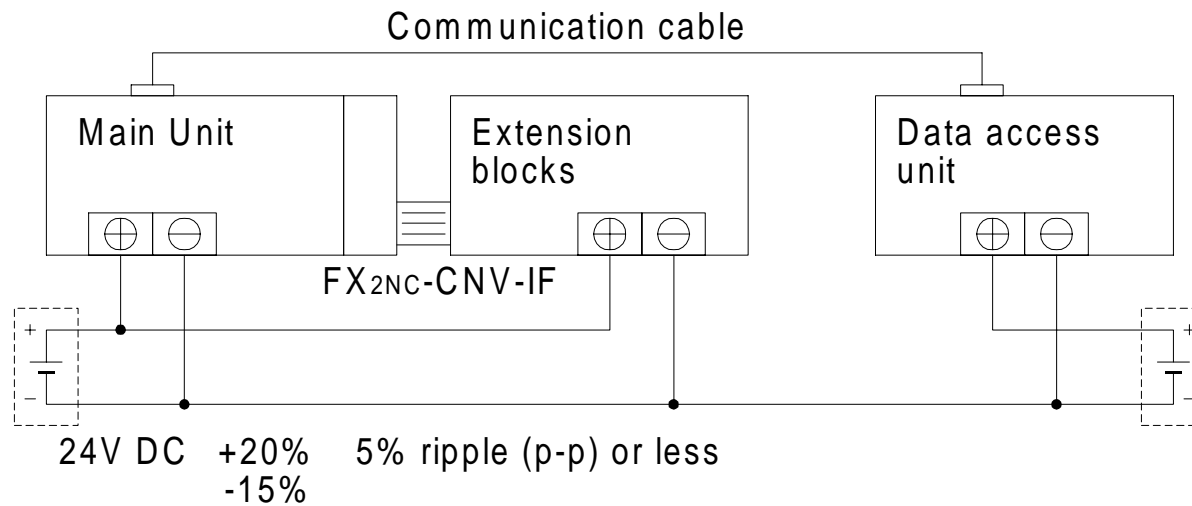

4.2 Earthing / Grounding



Use a cable at least 0.2mm^2 (AWG24) to ground equipment. Ground resistance must be less than 100Ω (class D). Note that the ground cable must not be connected to the same ground as the power circuits. Grounding is recommended but if a proper ground cannot be provided the PLC will still operate correctly.

1	INTRODUCTION
2	TERMINAL LAYOUTS
3	INSTALLATION NOTES
4	POWER SUPPLY
5	INPUTS
6	OUTPUTS
7	DIAGNOSTICS

5. Inputs

5.1 24V DC input specifications

Table 5.1 :FX2NC input specifications

		FX2NC main unit, extension block		FX0N, FX2N Extension block
		X0 → X7	X10 → ∞	
Input voltage		24V DC +20%, -15%		
Input current		24V DC, 7mA	24V DC, 5mA	24V DC, 5mA
Input switching current	OFF → ON	>4.5mA	>3.5mA	>3.5mA
	ON → OFF	<1.5mA		
Response time		10ms		
Variable response time		X000-X017 0-60ms (FX2NC-16M★ : X000-X007)		---
Circuit isolation		Photocoupler		
Operation indication		LED is lit		

5.1.1 Typical wiring

Figure 5.1: source

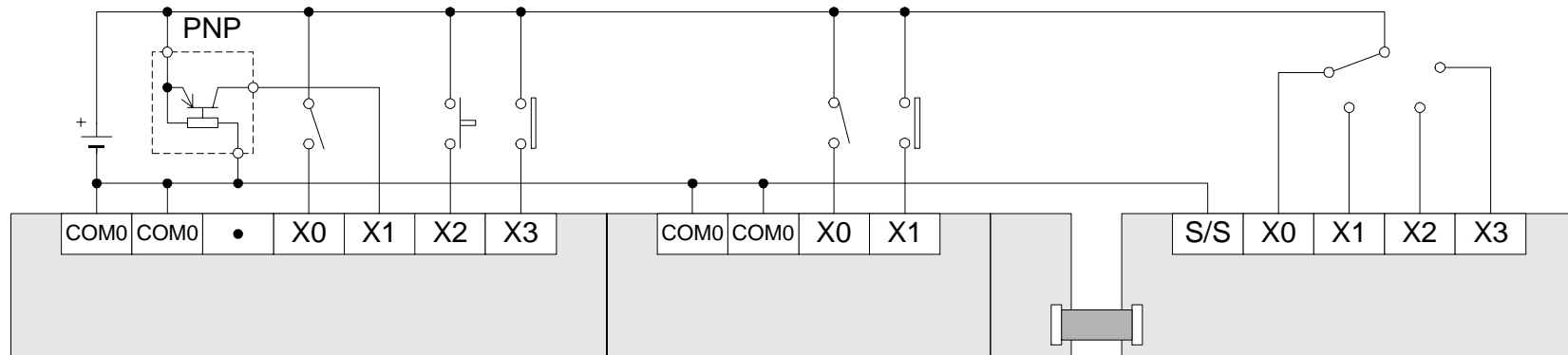

Figure 5.2: sink

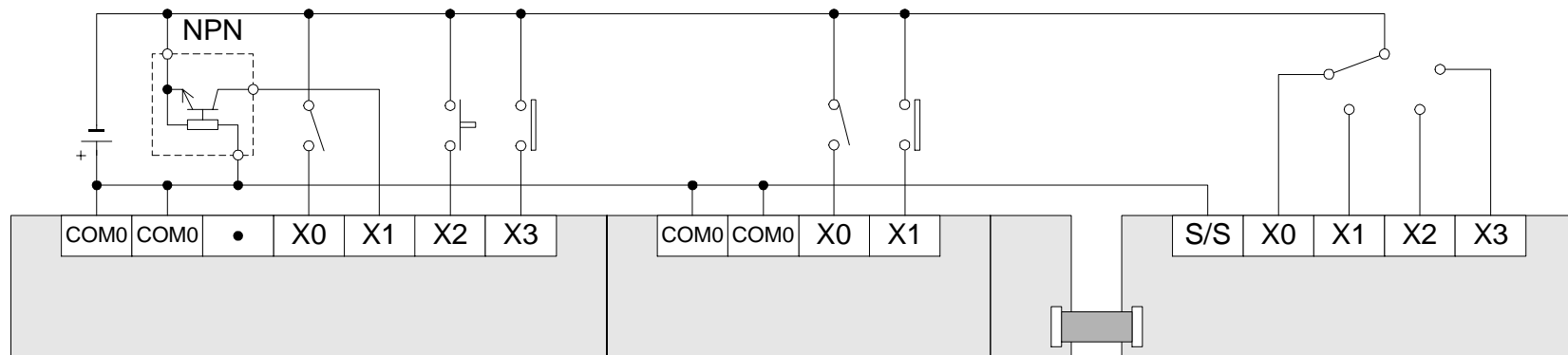

Table 5.2 : Item check

①	External power supply 24V DC +20% -15%
②	PNP (NPN) proximity sensor
③	Switch
④	Push button
⑤	Contact
⑥	Rotary switch
⑦	MPU main processing unit (main unit)
⑧	FX2NC Extension block
⑨	FX2NC-CNV-IF Connector conversion adapter
⑩	FX0N, FX2N Extension block

5.1.2 Input circuit connection

Figure 5.3: FX2NC Main unit and FX2NC Extension block

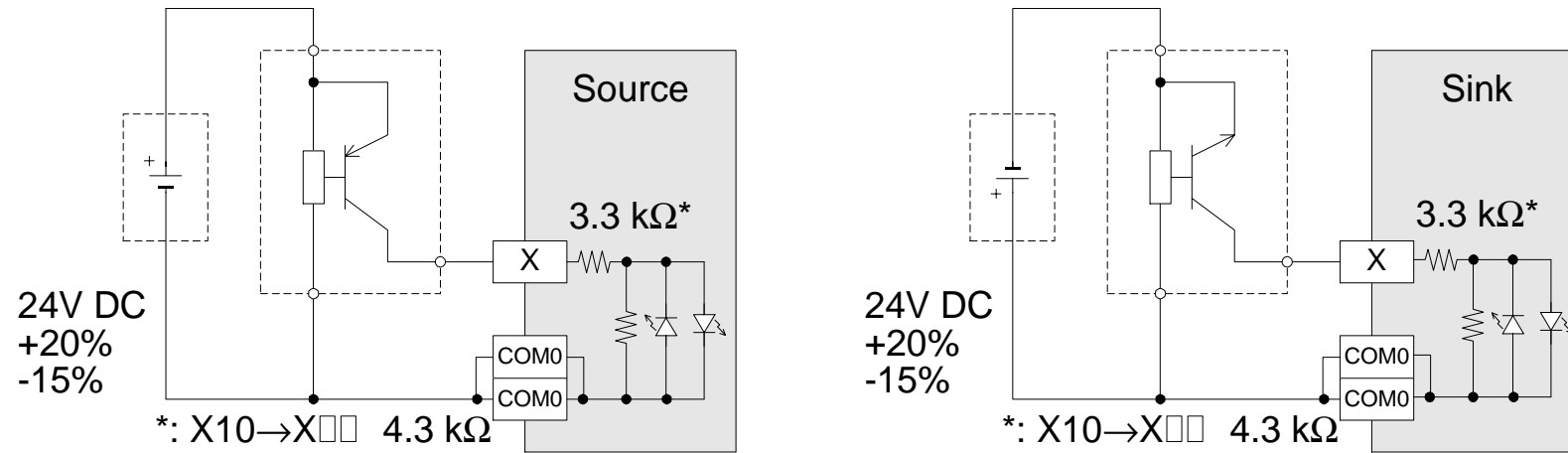
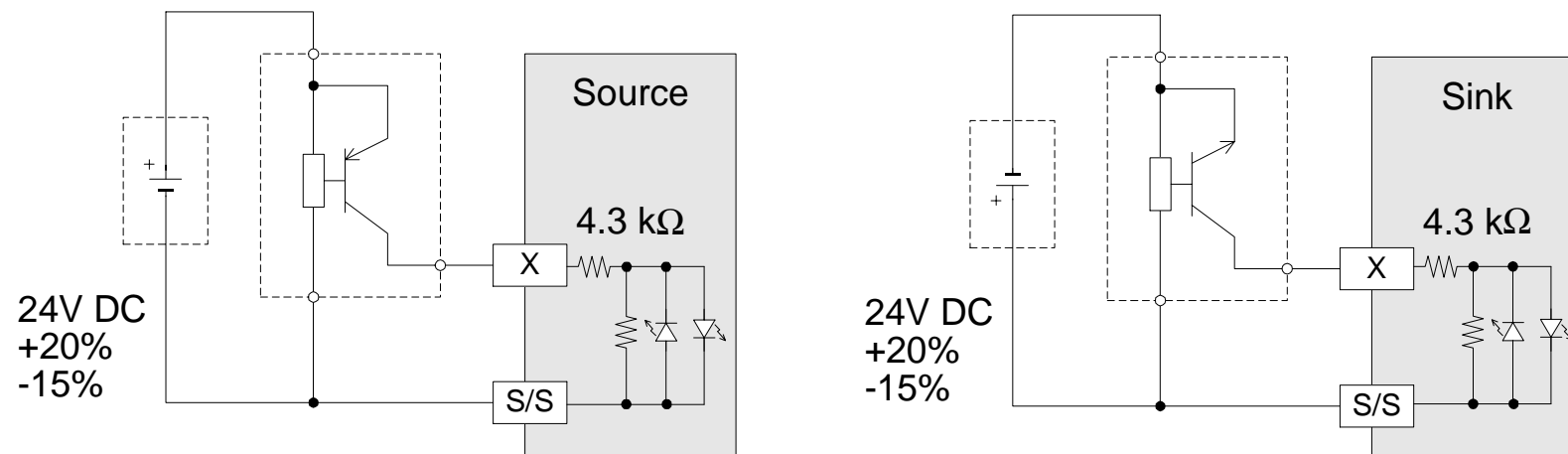

Figure 5.4: FX2N and FX0N Extension block



5.1.3 Diodes and inputs connected in series;

Vdrop across the diode Max. 4V

No more than 2 LEDs should be connected in series.

Figure 5.5: Series diodes

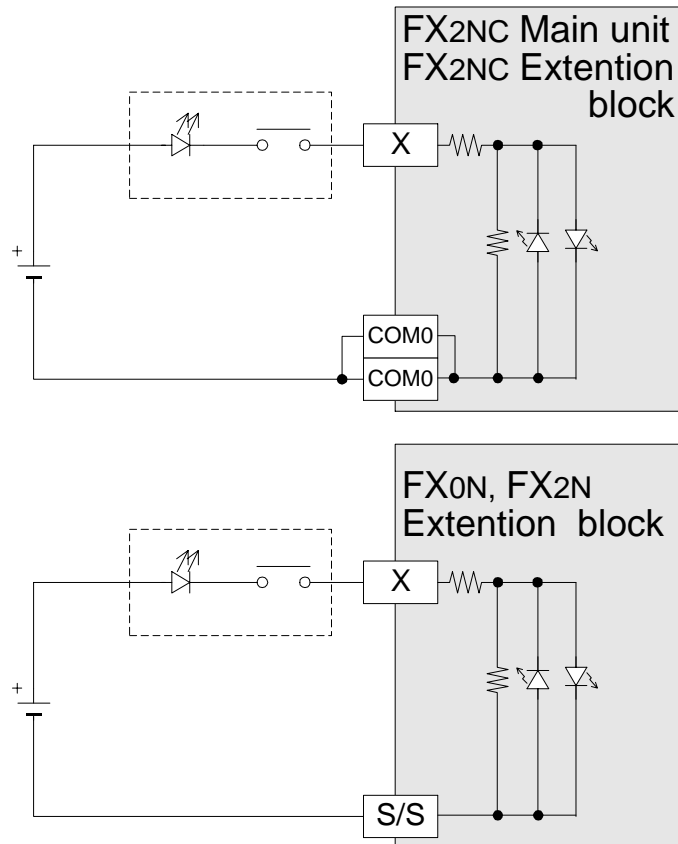

5.1.4 Resistors and inputs connected in parallel;

Parallel resistance R_p : $FX_{2NC} = 15k\Omega$. If resistance R_p is less than the stated value, then add R_b . See equation 1 for R_b calculation.

Alternatively; Current leakage: $FX_{2NC} = 1.5mA$. If the current leakage is greater than the stated value, then add R_b . See equation 2 for R_b calculation.

Figure 5.6: Parallel LED

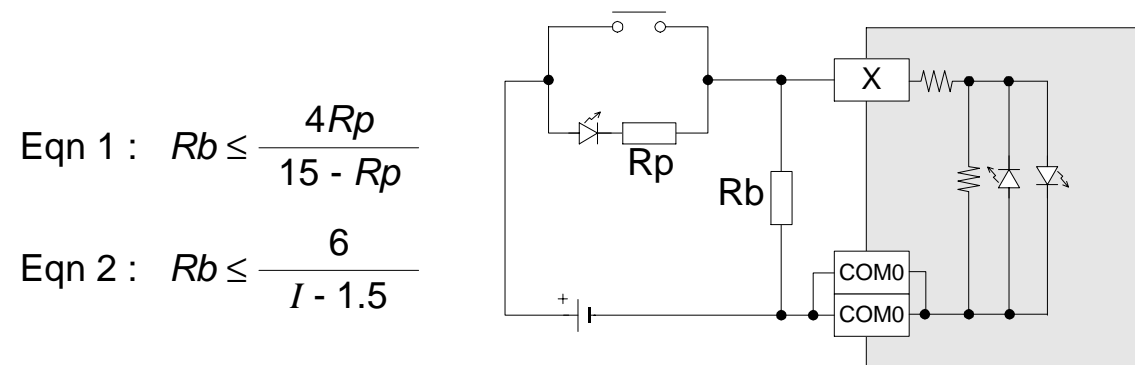

5.2 AC110V input Extension block

Table 5.3 : FX_{0N}-8EX-UA1/UL, FX_{2N}-8EX-UA1/UL input specification

Input voltage	85-132V AC 50/60Hz
Input impedance	21kΩ/50HZ 18kΩ/60Hz
Input current	4.7mA 100V AC/50Hz 6.2mA 110V AC/60Hz
OFF → ON/ON → OFF; input switching current	80V 3.8mA/30V 1.7mA
Response time	25ms
Circuit isolation / Operation indication	Photocoupler/LED is lit

5.2.1 Input circuit connection

Figure 5.7: FX_{0N}-8EX-UA1/UL, FX_{2N}-8EX-UA1/UL

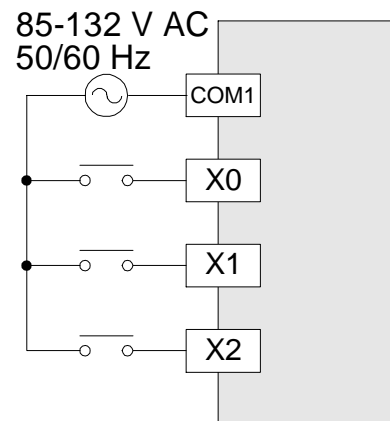

5.2.2 Programming caution



When using 110V AC units, high speed counter and interrupt routines are not suitable for use due to the long 'ON/OFF' times. The following instructions are also not suitable.

FNC 51 REFF	FNC 70 TKY
FNC 52 MTR	FNC71 HKY
FNC 56 SPD	FNC 72 DSW
FNC 68 ROTC	FNC 75 ARWS

1	INTRODUCTION
2	TERMINAL LAYOUTS
3	INSTALLATION NOTES
4	POWER SUPPLY
5	INPUTS
6	OUTPUTS
7	DIAGNOSTICS

6. Outputs

6.1 Transistor output specification

Table 6.1 :

Switched voltage (resistive load)		5-30V DC
Rated current / N points (resistive load)		FX2NC Main unit, Extension block: 0.1A/1point, 0.8A/8point, 0.3A/1point (Y0-Y3) FX0N, FX2N Extension block: 0.5A/1point, 0.8A/4point, 1.6A/8point
Max. Inductive load		FX2NC Main unit, Extension block: 2.4W/24V DC, 7.2W/24V DC (Y0-Y3) FX0N, FX2N Extension block: 12W/24V DC
Response time (approx.)	OFF → ON	<0.2ms (100mA/24V DC), <15μs (100mA/5V DC) (Y0,Y1)
	ON → OFF	<0.2ms (100mA/24V DC), <30μs (100mA/5V DC) (Y0,Y1)
Open circuit current leakage		0.1mA/30V DC
Circuit isolation		Photocoupler
Operation indication		LED is lit when photocoupler is driven

6.1.1 Response times

OFF times increase as the load current decreases.

For improved response times use a 'dummy' resistor, see Figure 6.1. If a response time of 0.5 ms or better is required when using 'light loads' use a 'dummy' resistor and ensure the signal line has a current greater than 60mA/24V DC.

Figure 6.1 :Dummy load

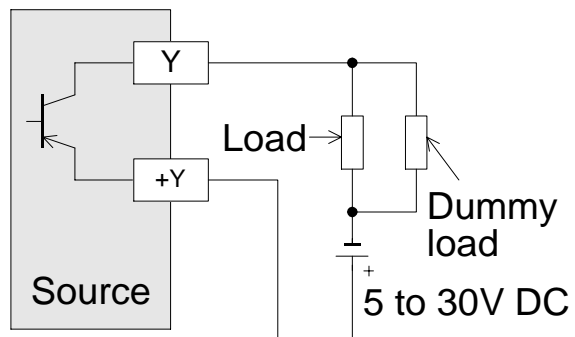

6.1.2 Transistor output example

Typical wiring to 4-point common type.

Figure 6.2:World Spec. (Source)

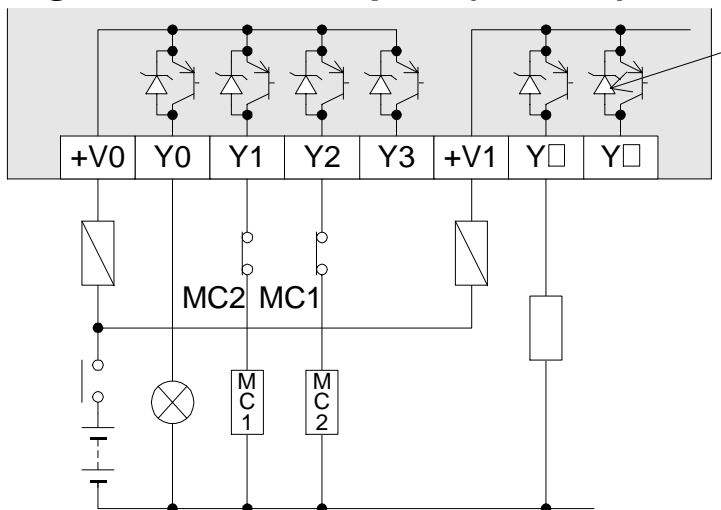
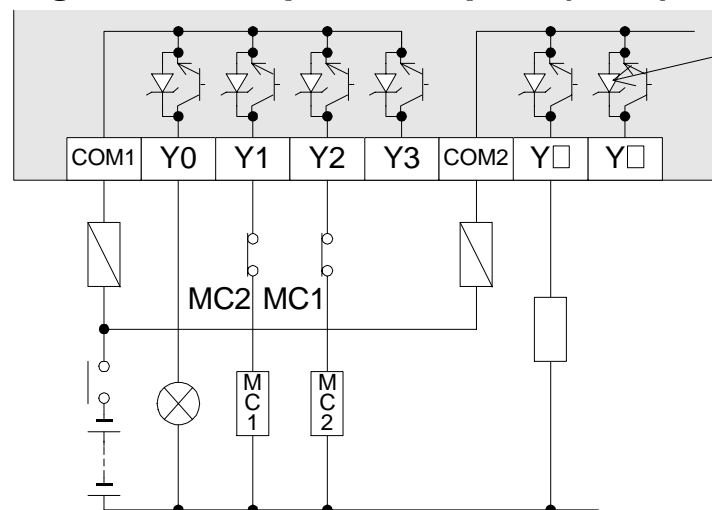

Figure 6.3 :Japanese Spec. (Sink)



Common points (See sec, 2.1, 2.2, 2.3)

- FX2NC-16MT-DSS : 8 points (+V0 See sec, 3.12)
- FX2NC-32/64/96MT-DSS, FX2NC-16/32EYT-DSS :
16 points (+V0 to +V2 See sec, 3.12)
- FX2N-16EYT-ESS/UL : 8 points (+V0, +V1)
- FX2N-8EYT-ESS/UL : 4 points (+V0, +V1)
- FX0N Extension blocks : 4 points (+V0 to +V3)

Table 6.2 : Item check

①	DC power supply	③	External, mechanical inter-lock
②	Fuse	④	Internal noise suppressor

Typical wiring to 8 and 16-point common type.

Figure 6.4 :World Spec. (Source)

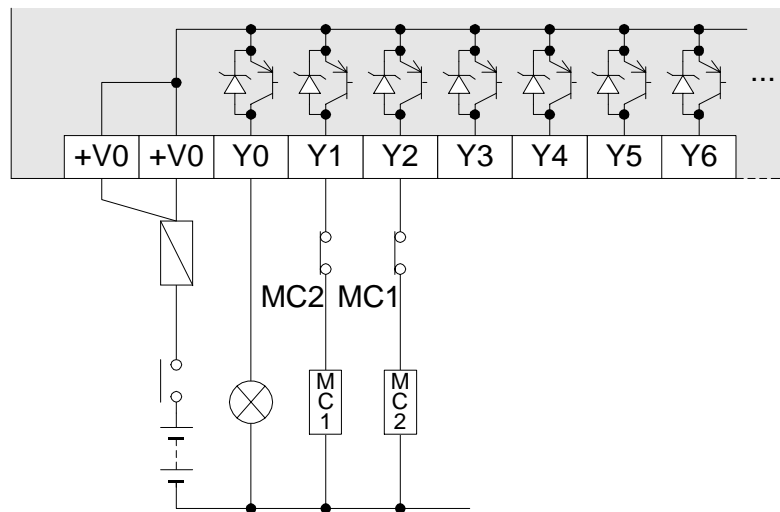

Figure 6.5 :Japanese Spec. (Sink)

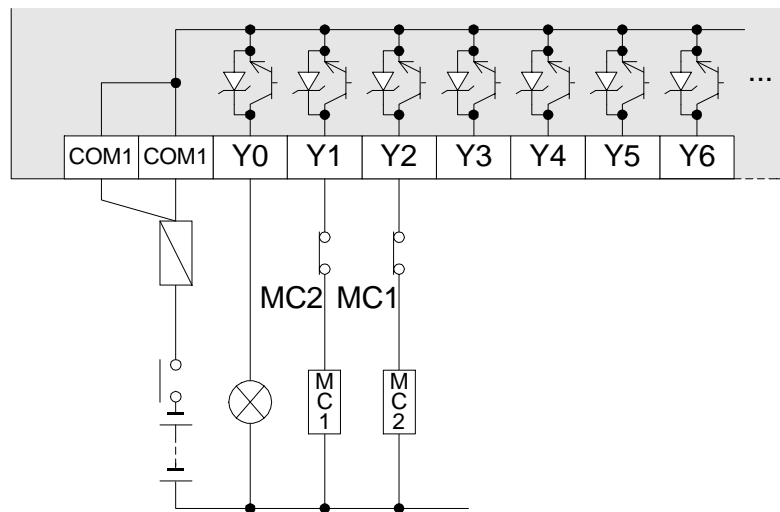

Table 6.3:Item check

	DC power supply
	Fuse
	External, mechanical inter-lock
	The output connectors of the main unit and the connector-type 16-point output extension blocks are the 16-point common type (8-point common type for the FX2NC-16MT). These output connectors have two +V0 to +V2 pins that are connected to each other inside the programmable controller. To connect the line to an external unit, shortcircuit these two pins at the external circuit so that the load of each pin can be reduced.

6.2 Relay output specification

Table 6.4 :

Switched voltages (resistive load)		≤ 240V AC, ≤ 30V DC
Rated current / N points (resistive load)		<ul style="list-style-type: none"> FX2NC:Main units and Extension blocks 2A/1point, 4A/1COM(8A/2COM) (See sec, 3.13, 6.2.2)
		<ul style="list-style-type: none"> FX2N ,FX0N:Extension blocks 2A/1point, 8A/COM
Max. Inductive load		80VA See table 6.5
Max. lamp load (tungsten load)		100W (1.17A/85V AC, 0.4A/250V AC)
Minimum load		When supply voltage < 24V DC allow at least 5mA flow
Response time (approx.)	OFF → ON	10ms
	ON → OFF	10ms
Circuit isolation		by relay
Operation indication		LED is lit when coil is energized

6.2.1 Reliability tests



The test results in table 6.4 were gathered from a 1 sec ON/OFF test cycle. Please note that the over current induced by in-rush greatly reduces the relay contacts service life. The rated life for an inductive AC load such as a contactor or solenoid valve is 500,000 operations at 20VA.

Table 6.5 :

	20VA	35VA	80VA
Load capacity	0.2A/100VAC 0.1A/200VAC	0.35A/100V AC 0.17A/240V AC	0.8A/100V AC 0.4A/240V AC
Life of contact (cycles)	3,000,000	1,000,000	200,000
Example load (Mitsubishi contactor)	S-K10 to S-K95	S-K100 to S-K150	S-K180,S-K400

6.2.2 Relay output example

Figure 6.6: Typical wiring to the 4-point common type

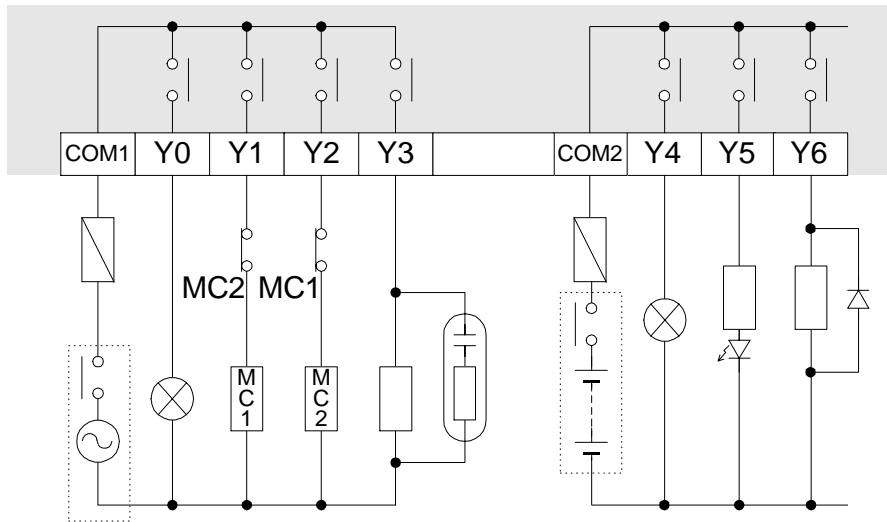

Table 6.6 : Item check

①	AC power supply
②	Fuse
③	Solenoid valve
④	Incandescent lamp
⑤	Neon lamp
⑥	Contactors
⑦	Noise suppressor 0.1μF capacitor + 100-120Ω resistor
⑧	DC power supply
⑨	LED
⑩	Surge absorbing diode



Common points (See sec, 2.1, 2.2, 2.3)

- FX₂NC-16MR-T-DS : 4points (COM1, COM2)
- FX₂NC-16EYR-T-DS : 8points (Tow COM1, Tow COM2 See sec, 3.13)
- FX₂N-16EYR-ES/UL : 8points (COM1, COM2)
- FX₂N-8EYR-ES/UL, FX₂N-8ER-ES/UL : 4points (COM1, COM2)
- FX₀N Extension blocks : 4points (COM1 to COM4)

Figure 6.7 :Typical wiring to the 8-point common type

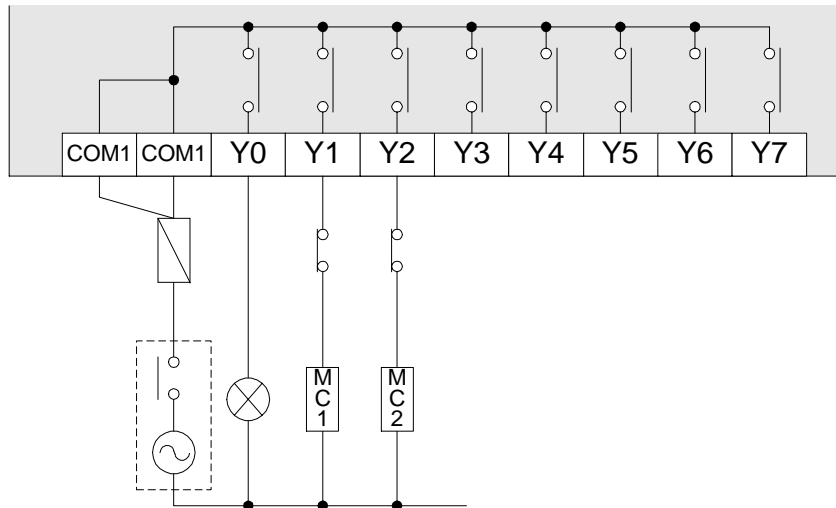

Table 6.7 :Item check

	AC power supply
	Fuse
	The output terminal block in the FX2NC-16EYR-T-DS has two COM1 or COM2 pins that are connected to each other inside the main unit. To connect the line to an external unit, shortcircuit these two pins at the external circuit so that the load applied on each pin can be reduced.
	Incandescent lamp

6.3 Triac (SSR) output specifications

Table 6.8 :

Switched voltages (resistive load)		85-242V AC
Rated current / N points (resistive load)		0.3A/1point, 0.8A/COM
Max. Inductive load		15VA/100V AC, 36VA/240V AC
Max. lamp load (tungsten load)		30W (0.35A/85V AC, 0.12A/242V AC)
Minimum load		0.4VA/100V AC, 2.3VA/240V AC
Open circuit current leakage		1mA/100V AC, 2.4mA/240V AC
Response time (approx.)	OFF→ON	<1ms
	ON→OFF	<10ms
Circuit isolation		by photocoupler
Operation indication		LED is lit when photocoupler is driven

6.3.1 In-rush currents

These currents should be kept as low as possible. The root mean square (I_{rms}) $< 0.2A$. Reference Eqn 1 for (I_{rms})

I_r -In-rush current (A)

T_r -In-rush time (sec)

I_s -Switch current (A)

T_s -Switch time (sec)

T_f -Operation time (sec)

Eqn 1

$$I_{rms} = \sqrt{\frac{I_r^2 \times T_r + I_s^2 \times T_s}{T_r + T_s + T_f}}$$

Ex.

$$0.2A = \sqrt{\frac{4^2 \times 0.02 + 0.4^2 \times 0.7}{0.02 + 0.7 + 10}}$$

Figure 6.9 :Current graph

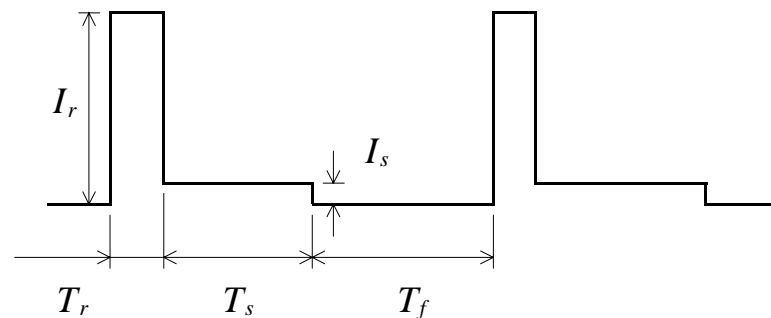

6.3.2 Triac output example

Figure 6.10: Typical wiring

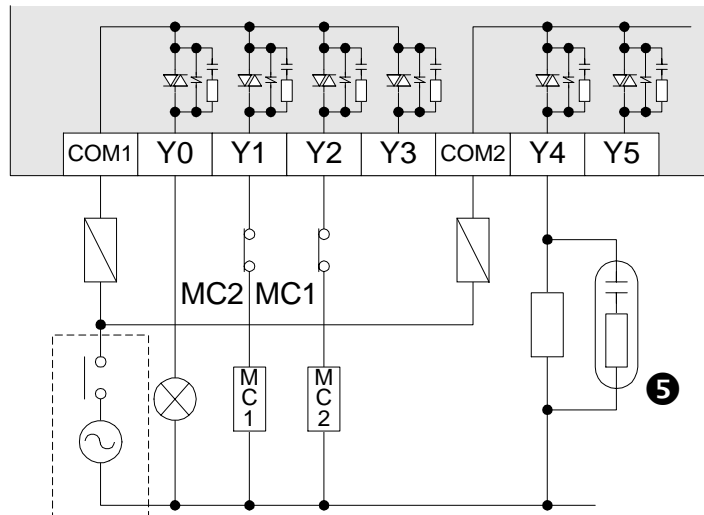

Table 6.9: Item check

①	AC power supply
②	Fuse
③	Solenoid valve
④	Incandescent lamp
⑤	Noise suppressor 0.1µF capacitor+100-120Ω resistor

6.4 Applying safe loads



Ensure all loads are applied to the same side of each PLC output, see previous figures. Loads which should NEVER simultaneously operate (e.g. direction control of a motor), because of a safety critical situation, should not rely on the PLC's sequencing alone. Mechanical interlocks MUST be fitted to all safety critical circuits. (See preceding figure.)

MEMO

1	INTRODUCTION
2	TERMINAL LAYOUTS
3	INSTALLATION NOTES
4	POWER SUPPLY
5	INPUTS
6	OUTPUTS
7	DIAGNOSTICS

7. Diagnostics

7.1 Preliminary checks

POWER <input type="checkbox"/> RUN <input type="checkbox"/> BATT <input type="checkbox"/> ERROR <input type="checkbox"/>	Check power supply, ground and I/O cables are wired correctly.
POWER <input checked="" type="checkbox"/> RUN <input type="checkbox"/> BATT <input type="checkbox"/> ERROR <input type="checkbox"/>	Turn the power supply on. Check the power LED is lit. Down load a small test program into the PLC using a handheld programmer or MEDOC. Verify the program to ensure it has been written to the PLC correctly. Using the programming device force ON/OFF each output. Check the output LEDs for operation.
POWER <input checked="" type="checkbox"/> RUN <input checked="" type="checkbox"/> BATT <input type="checkbox"/> ERROR <input type="checkbox"/>	Put the PLC into RUN. Check the RUN LED is lit. Check the previously down loaded program works correctly. Once all check are complete take the PLC out of run and turn OFF the power supply.
	During this testing stage take extrem care not to touch any live or hazardous parts.

7.2 Basic diagnostics

The following diagnostic functions will help identify, common faults.

7.2.1 BATT LED ON

POWER ■ RUN ■ BATT ■ ERROR □	Fault BATT LED ON	Remedy Monitor M8006 with a programming tool.	Possible results	M8006:ON	If the current program and/or date is stored only in the PLCs RAM, copy and store this immediately. Proceed to replace the PLCs battery.
				M8006:OFF	Monitor D8005. This is the current battery voltage (in 0.1V units). Contact a Mitsubishi service center for further consideration of the problem.

7.2.2 ERROR LED flashes (PROGRAM ERROR)

POWER ■ RUN □ BATT □ ERROR ■	Fault ERROR LED flashes	Remedy Check BATT LED.	Possible results	LED OFF	Is the BATT OK? Work through BATT diagnostic. If the BATT LED is cured yet the ERROR LED still flashes check for a programming problem.
				LED is lit	Check for programming problem.

7.2.3 ERROR LED ON (CPU ERROR)

POWER ■ RUN □ BATT □ ERROR ■	Fault ERROR LED ON	Remedy Reset PLC. Power OFF,ON and trigger RUN input.	Possible results	LED OFF	Has the memory cassette been installed or removed while the units has still been powered? (A)
				LED is lit	

(A)	Remedy Power OFF Disconnect earth/ ground terminal Power ON	Possible results	LED is lit	(B)
			LED is flashing	Check for programming error. Ensure the earth/ ground cable is correctly rewired.

(B)	Remedy Possible program/scan time error. Check D8012 for program scan time, (units 0.2 msec must be less than 0.2 sec, i.e data value <2000).	Possible results D8012 > D8000
-----	--	-----------------------------------

7.3 Common errors

- Corroded contact points at some point in an I/O line.
- An I/O device has been used outside its specified operating range.
- An input signal occurs in a shorter time period that taken by one program scan.

7.4 Replacing the battery

Turn OFF PLC's power supply. Remove sidecover from the PLC. Remove battery from holder-disconnect and replace (this should be carried out in 20 sec if the current data held in the PLC's RAM is not to be lost). Refit battery and cover.

Figure 7.1: Battery (FX2NC-32BL)

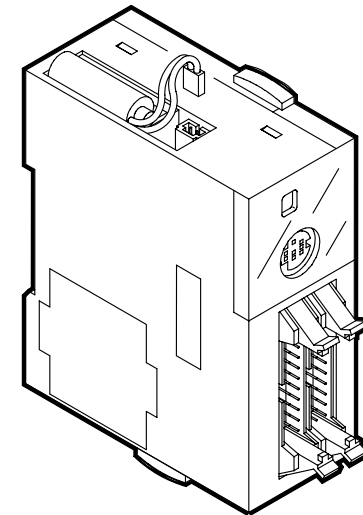

7.5 Maintenance

- Battery has a 3 year life.
- Check interior temperature of the panel.
- Check panel air filters if fitted.
- Check for loosening of terminals or mounting facilities (due to vibration).

7.6 Error flags ON indicates error.

M8004 (ref. 8004)	Error occurrence (ON when M8060-7 are ON)
M8005	Battery voltage abnormally low
M8006 (ref. D8005/6)	Latched low battery voltage flag
M8007 (ref. D8007/8)	Momentary power failure
M8008 (ref. D8008)	Power failure (see Figure 7.2)
M8009 (ref. D8009)	24V DC OFF
M8030	Battery LED OFF - Battery voltage low
M8035	Forced RUN mode
M8036	Forced RUN signal
M8037	Forced STOP signal
M8039 (ref. D8039)	Constant scan mode

M8060 (ref. D8060)	I/O configuration error
M8061 (ref. D8061)	PLC hardware error
M8062 (ref. D8062)	PLC/programming device communication error
M8063 (ref. D8063)	Parallel link error
M8064 (ref. D8064)	Parameter error
M8065 (ref. D8065, D8069)	Syntax error
M8066 (ref. D8066, D8069)	Program (circuit) error
M8067 (ref. D8067, D8069)	Program execution error
M8068 (ref. D8068)	Execution error latch
M8069 (ref. D8069)	I/O bus check

Figure 7.2: Power down and its associated flags

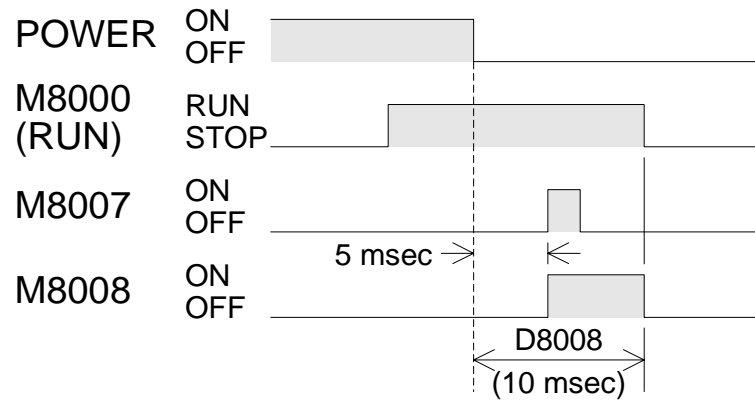

7.7 Error registers

D8000 (default 200msec)	Watchdog timer
M8001	PLC version 24201=FX2NC/FX2N V2.01 (24=FX2NC/FX2N, 201=V2.01)
M8002	Memory capacity 02=2K steps, 04=4K steps, 08=8K(16K) steps
M8003	Memory type 02H=EEPROM protect switch OFF 0AH=EEPROM protect switch ON 10H=MPU memory
M8004	Error flag number 8060=M8060, (8060-8068)
M8005	Battery voltage 36=3.6V (units 0.1V)
D8006 (default 3.0V)	Low battery detection level
D8007	Number of momentary power failures - reset on full power OFF

D8008	Power failure detection period (Automatically corrected)
D8009	Lowest device affected by 24V DC power failure

D8060	Reports location of I/O configuration error (see Figure 7.3)
D8061	Error code for PLC hardware error
D8062	Error code number for programmer communications fault
D8063	Error code for parallel link fault
D8064	Parameter error code
D8065	Syntax error code
D8066	Program (circuit) error code
D8067	Program execution error code
D8068	Latched step number of execution error
D8069	Step number of errors associated with error flags M8065-M8067

Figure 7.3:
I/O configuration error, A) number, B) type.

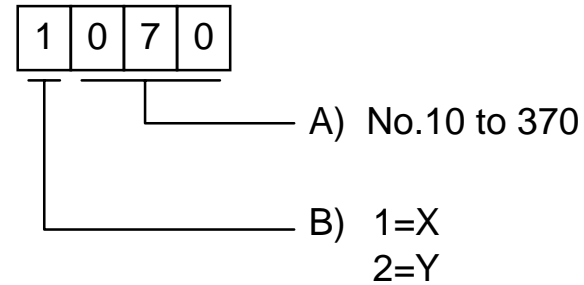

7.8 Error codes

D8061	Check cable connections
0000	No error
6101	RAM error
6102	Operation circuit error
6103	I/O bus error (M8069 = ON)
D8062	Check the programmer / PLC connections
0000	No error
6201	Parity/overrun/framing error
6202	Character error
6203	Data sum check error
6204	Data format error
6205	Command error

D8063	Check both power and communications connections
0000	No error
6301	Parity/overrun/framing error
6302	Character error
6303	Data sum check error
6304	Data format error
6305	Command error
6306	Watchdog timer error

7.9 Instruction list

Table 7.1: Numerically sorted

		0	1	2	3	4	5	6	7	8	9
000	PROGRAM FLOW	CJ	CALL	SRET	IRET	EI	DI	FEND	WDT	FOR	NEXT
010	TRANSFERS, COMP	CMP	ZCP	MOV	SMOV	CML	BMOV	FMOV	XCH	BCD	BIN
020	+·×÷, LOGICS	ADD	SUB	MUL	DIV	INC	DEC	WAND	WOR	WXOR	NEG
030	ROTATION, SHIFT	ROR	ROL	RCR	RCL	SFTR	SFTL	WSFR	WSFL	SFWR	SFRD
040	DATA OPERATION 1	ZRST	DECO	ENCO	SUM	BON	MEAN	ANS	ANR	SQR	FLT
050	HIGH-SPEED	REF	REFF	MTR	HSCS	HSCR	HSZ	SPD	PLSY	PWM	PLSR
060	HANDY INSTR. 1	IST	SER	ABSD	INCD	TTMR	STMR	ALT	RAMP	ROTC	SORT
070	FX I/O DEVICES	TKY	HKY	DSW	SEGD	SEGL	ARWS	ASC	PR	FROM	TO
080	FX SER DEVICES	RS	PRUN	ASCI	HEX	CCD	VRRD	VRSC	-	PID	-
110	FLOATING POINT 1	ECMP	EZCP	-	-	-	-	-	-	EBCD	EBIN
120	FLOATING POINT 2	EADD	ESUB	EMUL	EDIV	-	-	-	ESQR	-	INT
130	FLOATING POINT 3	SIN	COS	TAN	-	-	-	-	-	-	-
140	DATA OPERATION 2	-	-	-	-	-	-	-	SWAP	-	-
160	REAL TIME CLOCK	TCMP	TZCP	TADD	TSUB	-	-	TRD	TWR	-	-
170	GREY CODES	GRY	GBIN	-	-	-	-	-	-	-	-
220	IN-LINE COMPARE	-	-	-	-	LD=	LD>	LD<	-	LD≠	LD≤
230		LD≥	-	AND=	AND>	AND<	-	AND≠	AND≤	AND≥	-
240		OR=	OR>	OR<	-	OR≠	OR≤	OR≥	-	-	-

Table: 7.2 Alphabetically sorted

	Symbol	FNC No.	D	P
A	ABSD	062		
	ADD	020		
	ALT	066		
	AND□	232-238		
	ANR	047		
	ANS	046		
	ARWS	075		
	ASC	076		
	ASCI	082		
B	BCD	018		
	BIN	019		
	BMOV	015		
	BON	044		
C	CALL	001		
	CCD	084		
	CJ	000		
	CML	014		
	CMP	010		
	COS	131		

	Symbol	FNC No.	D	P
D	DEC	025		
	DECO	041		
	DI	005		
	DIV	023		
	DSW	072		
E	EADD	120		
	EBCD	118		
	EBIN	119		
	ECMP	110		
	EDIV	123		
	EI	004		
	EMULL	122		
	ENCO	042		
	ESQR	127		
ESUB	121			
F	EZCP	111		
	FEND	006		
	FLT	049		
	FMOV	016		
	FOR	008		
FROM	078			

	Symbol	FNC No.	D	P
G	GBIN	171		
	GRY	170		
H	HEX	083		
	HKY	071		
	HSCR	054		
	HSCS	053		
I	HSZ	055		
	INC	024		
	INCD	063		
	INT	129		
	IRET	003		
L	IST	060		
	LDO□	224-230		
M	MEAN	045		
	MOV	012		
	MTR	052		
N	MUL	022		
	NEG	029		
O	NEXT	009		
	OR□	240-246		

	Symbol	FNC No.	D	P
P	PID	088		
	PLSR	059		
	PLSY	057		
	PR	077		
	PRUN	081		
	PWM	058		
R	RAMP	067		
	RCL	033		
	RCR	032		
	REF	050		
	REFF	051		
	ROL	031		
	ROR	030		
	ROTC	068		
RS	080			
S	SEGD	073		
	SEGL	074		
	SER	061		
	SFRD	039		
	SFTL	035		
	SFTR	034		

	Symbol	FNC No.	D	P
S	SFWR	038		
	SIN	130		
	SMOV	013		
	SORT	069		
	SPD	056		
	SQR	048		
	SRET	002		
	STMR	065		
	SUB	021		
	SUM	043		
T	SWAP	147		
	TADD	162		
	TAN	132		
	TCMP	160		
	TKY	070		
	TO	079		
	TRD	166		
	TSUB	163		
	TTMR	064		
	TWR	167		
TZCP	161			

	Symbol	FNC No.	D	P
V	VRRD	085		
	VRSC	086		
W	WAND	026		
	WDT	007		
	WOR	027		
	WSFL	037		
X	WSFR	036		
	WXOR	028		
Z	XCH	017		
	ZCP	011		
	ZRST	040		

		FX2NC		
Program capacity		Built-in memory(RAM) = 8K steps FX2NC-EEPROM-4C = 2K - 4K steps FX2NC-EEPROM-16 = 2K - 16K steps FX2NC-EEPROM16C = 2K - 16K steps		
Input (X) relay		X0 - 267 (184 pnts)	(X + Y) ≤ 256 pnts Max.	
Output (Y) relay		Y0 - 267 (184 pnts)		
Auxiliary relay (3072 pnts, + 256 pnts)		M0-M499 (500 pnts)	Battery backup by Parameters	
	Battery backup	M500-M1023 (524 pnts)		
	Battery backup	M1024-M3071 (2048 pnts)		
	Special function	M8000-M8255 (256 pnts)		
State relay (1000 pnts)		S0-S499 (500 pnts)	Battery backup by Parameters	
	Battery backup	S500-S999 (500 pnts) (S900-S999 ANS FNC46)		
Timer (256 pnts)	100 ms		T0-T199 (200 pnts)	
	10 ms		T200-T245 (46 pnts)	
	1 ms	Battery backup	T246-T249 (4 pnts)	
	100 ms		T250-T255 (6 pnts)	

		FX2NC	
Counter (256 pnts)	16 bit	C0-C99 (100 pnts)	Battery backup by Parameters
	16 bit	C100-C199 (100 pnts)	
	32 bit	C200-C219 (20 pnts)	Battery backup by Parameters
	32 bit	C200-C234 (15 pnts)	
		C235-C245	
		C246-C250	
		C251-C255	
Data register (8000 pnts, + 256 pnts)		D0-D199 (200 pnts)	Battery backup by Parameters
	Battery backup	D200-D511 (312 pnts)	
	Battery backup	D512-D7999 (7488 pnts)	D1000-D7999 File register by Parameters
	Special function	D8000-D8255 (256 pnts)	
	Index	V0-V7, Z0-Z7 (16 pnts)	
Pointer	CALL (FNC 01)	P0-P127 (128 pnts)	
	EI (FNC 04)	I00□ - I50□, I6□□ - I8□□, I010 - I060 (6, 3, 6 pnts)	
Nesting	MC /MCR	N0 - N7 (8 pnts)	
Numbers	16 bit	32 bit	
K	-32,768 to 32,767	-2,147,483,648 to 2,147,483,647	
H	0 to FFFFH	0 to FFFFFFFFH	
Float	-	0, $\pm 1.175 \times 10^{-38}$ to $\pm 3.403 \times 10^{38}$	

HARDWARE MANUAL

FX2NC (DSS/DS) SERIES PROGRAMMABLE CONTROLLERS



HEAD OFFICE: TOKYO BUILDING, 2-7-3 MARUNOUCHI, CHIYODA-KU, TOKYO 100-8310, JAPAN
HIMEJI WORKS: 840, CHIYODA CHO, HIMEJI, JAPAN

MODEL	FX2NC-HW-E
MODEL CODE	09R509

JY992D76401G
(MEE)

Effective Nov. 2005
Specification are subject to change without notice.