

FX_{2N}

FX_{2N}-1HC SPECIAL FUNCTION BLOCK

USER'S GUIDE

JY992D65401E

This manual contains text, diagrams and explanations which will guide the reader in the correct installation and operation of the FX_{2N}-1HC special function block and should be read and understood before attempting to install or use the unit.

Further information can be found in the FX PROGRAMMING MANUAL and FX_{2N}, FX_{2NC}, FX_{3U}, FX_{3UC} SERIES HARDWARE MANUAL.

1. INTRODUCTION

The hardware high-speed counter block is a 2-phase 50 kHz high-speed counter. It is a special function block for the FX_{2N}, FX_{2NC}, FX_{3U}, FX_{3UC} series PLC.

- FROM/TO instruction transfers the PLC data (i.e. parameters, comparing value and present value).
- The FX_{2N}-1HC occupies 8 points of I/O on the FX_{2N}, FX_{2NC}, FX_{3U}, FX_{3UC} expansion bus. The 8 points can be allocated from either inputs or outputs.
- Differential-Line-Driver (AM26C31 or equivalent) and open collector output encoders are available for FX_{2N}-1HC.
- The source of your input signal should be a 1 or 2 phase encoder. A 5V, 12V, or 24V power source can be used. An initial value setting command input (PRESET) and a count prohibit command input (DISABLE) are also available.
- The FX_{2N}-1HC has two outputs. When the counter value coincides with an output compare value, the appropriate output is set ON. The output transistors are individually isolated to allow either sink or source connection methods.
- Various counter modes, such as 1-phase or 2-phase, 16-bit or 32-bit modes, can be selected using commands from the PLC. Allow the FX_{2N}-1HC unit to run only after setting these mode parameters.

1.1 External dimensions

Mass (weight): Approx. 0.3 kg (0.66 lbs) Dimensions: mm (inches)
Accessories: Self-adhesive labels special block number identification.

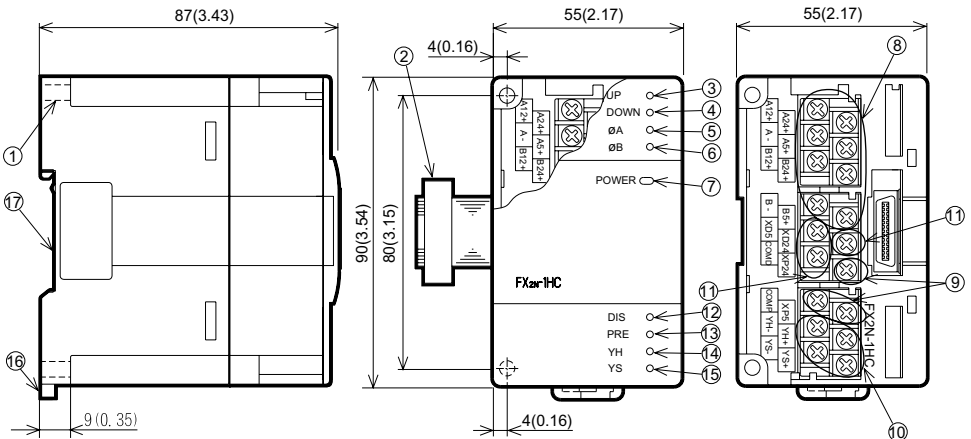

- ① Mounting hole 2-φ4.5 (0.18)
- ② Extension cable and connector
- ③ UP LED
- ④ DN (Down) LED
- ⑤ φA LED
- ⑥ φB LED
- ⑦ POWER LED
- ⑧ φA, φB terminal (M3 (0.12) screws)
- ⑨ PRESET terminal (M3 (0.12) screws)

- ⑩ YH-YS terminal (M3 (0.12) screws)
- ⑪ DISABLE terminal (M3 (0.12) screws)
- ⑫ DIS (DISABLE) LED
- ⑬ PRESET LED
- ⑭ YH LED
- ⑮ YS LED
- ⑯ DIN rail clip
- ⑰ Attachment groove for 35 (1.38) wide DIN rail

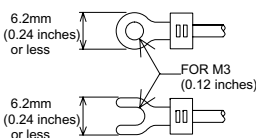

Industrial automation

Elinco Group

European Union: www.elinco.eu

Russia: www.elinc.ru

2. WIRING

PNP output encoders

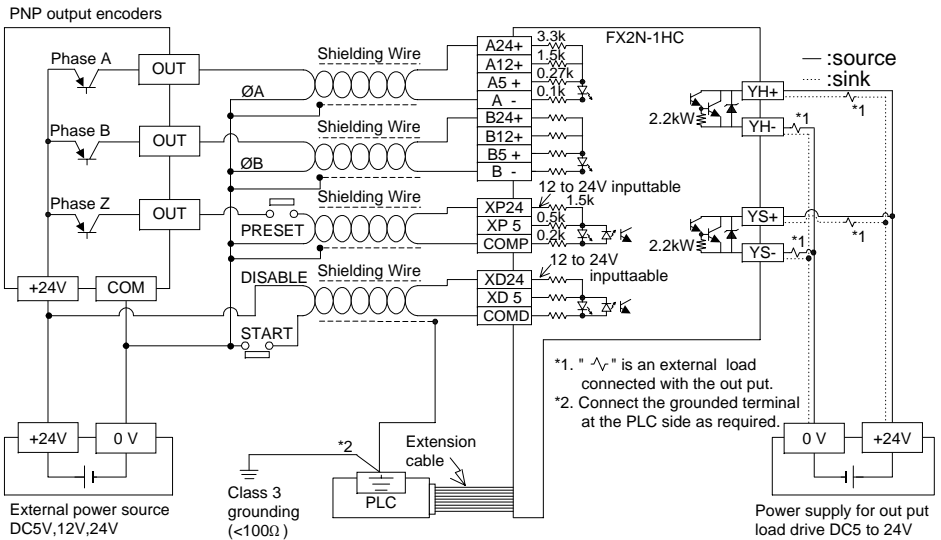

! If using on NPN output encoder please take care to match the polarity of the terminals of the encoder to those of the FX2N-1HC.

Differential-Line-Driver output encoders

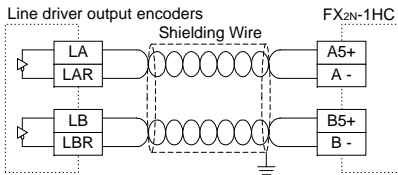

When applying the Differential-Line-Driver encoder (AM26C31 or equivalent) to FX2N-1HC, connect the encoder output with the 5V DC terminal as shown in the left figure.

Connect other terminals as shown in the PNP output encoder figure above.

3. SPECIFICATIONS

3.1 General specifications

! Perform the dielectric withstand voltage test between the GND terminal and all the other terminals short-circuited.

Item	Specification
General specifications (excluding the following)	Same as those for the FX2N main unit
Dielectric withstand voltage	500V AC, 1min (between all terminals and ground)

3.2 Performance specifications

Item	1-phase input		2-phase input			
	1 input	2 inputs	1 edge count	2 edge count	4 edge count	
Input signal	Signal level	Phase A, Phase B [A24+],[B24+] :24V DC±10% [A12+],[B12+] :12V DC±10% [A5+],[B5+] :3.0V to 5.5V DC PRESET, DISABLE [XP24],[XD24] :10.8V to 26.4V DC [XP5],[XD5] :5V DC±10% (Selected by terminal connection)	7mA or less 7mA or less 12.5mA or less 15mA or less 8mA or less			
	MAX. frequency	50 kHz	25 kHz	12.5kHz		
Pulse shape			t1 :Rise/fall time is 3μs or less t2 :ON/OFF pulse 6μs or more (at 50kHz) t3 :Phase difference between A and B is 3.5μs or more (at 50kHz) PRESET(Z phase) input 100μs or more DISABLE (count prohibit) input 100μs or more			
	Format	Automatic UP/DOWN (however, when on 1-phase 1-input mode, UP/DOWN is determined by a PLC command or an input terminal.)				
Counting specification	Range	When 32-bit is specified : -2,147,483,648 to +2,147,483,647 When 16-bit is specified : 0 to 65,535 (upper limit can be user specified)				
	Comparison Type	Each output is set when the present value of the counter matches with the compare value (which is transferred from the PLC), and is switched OFF by a reset command from the PLC. YH : Direct output processed by hardware. YS : Software processed output with worst delay time of 300μs. (Therefore, when the input frequency is 50 kHz, there is a worst case delay of 15 input pulses.)				
Output signal	Types of outputs	YH + : transistor output for YH output YH - : transistor output for YH output YS + : transistor output for YS output YS - : transistor output for YS output				
	Output capacity	5V to 24V DC 0.5A				
I/O occupation	8 points taken from the FX2n expansion bus (can be either inputs or outputs)					
Power from base	5V DC 90mA(Internal power supply from main unit or powered extension unit)					

3.3 Buffer memories (BFM)

BFM number		Contents	
Write	#0	Counter mode K0 to K11	Default: K0
	#1	DOWN/UP command (1-phase 1-input mode)	Default: K0
	#3,#2	Ring length Upper/Lower	Default: K65,536
	#4	Command	Default: K0
	#11,#10	Preset data Upper/Lower	Default: K0
	#13,#12	YH compare value Upper/Lower	Default: K32,767
	#15,#14	YS compare value Upper/Lower	Default: K32,767
Write / Read	#21,#20	Counter current value Upper/Lower	Default: K0
	#23,#22	Maximum count value Upper/Lower	Default: K0
	#25,#24	Minimum count value Upper/Lower	Default: K0
Read	#26	Compare results	
	#27	Terminal status	
	#29	Error status	
	#30	Model identification code K4010	

#5-#9, #16-#19, #28, #31 are reserved.

1) BFM #0 Counter mode (K0 to K11), BFM #1 DOWN/UP command

Count modes		32 bits	16 bits
2-phase input (phase difference pulse)	1 edge count	K0	K1
	2 edge count	K2	K3
	4 edge count	K4	K5
1-phase 2-input (add/subtract pulse)		K6	K7
1-phase 1-input	Hardware UP/DOWN	K8	K9
	Software UP/DOWN	K10	K11

The counter mode is selected from the PLC. As shown below, values between K0 and K11 are written to buffer memory BFM #0 from the PLC. When a value is written to BFM #0 the contents of BFM #1 to BFM #31 are reset to default values. When setting this value use a **TOP** (pulsed) instruction use M8002 (initial pulse) to drive the **TO** instruction.

A continuous command is not allowed.

a) 32-bit counter modes

A 32-bit binary counter which executes UP/DOWN counting will change from the lower limit value to the upper limit value or the upper limit value to the lower limit value when overflow occurs. Both the upper and lower limit values are fixed values: the upper limit value is +2,147,483,647, and the lower limit value is -2,147,483,648.

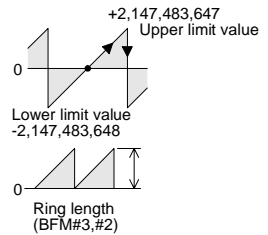

b) 16-bit counter modes

A 16-bit binary counter handles only positive values from 0 to 65,535. Changes to zero from the upper limit value or to the upper limit value from zero when overflow occurs; the upper limit value is determined by BFMs #3 and #2.

c) 1-phase 1-input counter (K8 to K11)

- Hardware UP/DOWN (K8, K9)

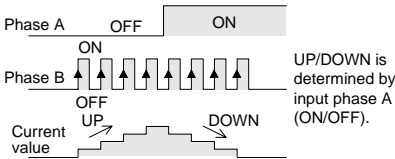

- Software UP/DOWN (K10, K11)

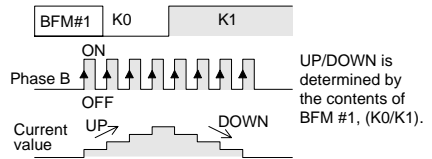

d) 1-phase 2-input counter (K6, K7)

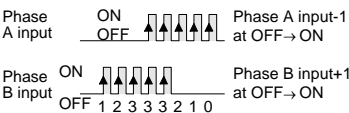

If both phase A and phase B inputs are received simultaneously, the counter value does not change.

e) 2-phase counter (K0 to K5)

- 1 edge-count (K0, K1)

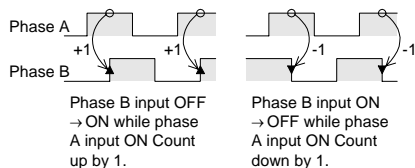

- 2 edge-count (K2, K3)

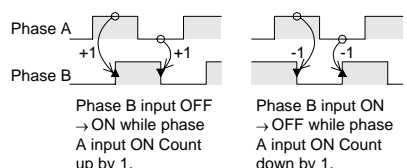

- 4 edge-count (K4, K5)

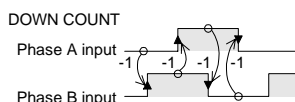
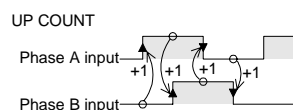

2) BFM #3, #2 Ring length

Stores the data that specifies the length of the 16-bit counter (default: K65,536).



In the above example, K100 is written into BFMs #3 and #2 of special block No.2 as a 32-bit binary value (BFM #3 = 0, BFM #2 = 100). Permitted values: K2 to K65,536.

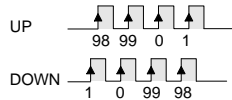

When ring length K100 is specified, the value of the counter changes as shown above.

Note: Write counter data with (D) TO

- Count data is always handled as a pair from two 16-bit values in this special function block. 16-bit 2's complement value stored in the registers of the PLC cannot be used.
- When you are writing a positive value between K32,768 and K65,535, the data should be treated as a 32-bit value even when a 16-bit ring counter is used.
- When transferring counter data to/from this special function block, always use the 32-bit forms of the FROM/TO instructions ((D) FROM, (D) TO).

3) BFM #4 Command

BFM#4	When '0'(OFF)	When '1'(ON)
b0	Count prohibit	Count permit
b1	YH output prohibit	YH output permit
b2	YS output prohibit	YS output permit
b3	YH/YS independent action	Mutual reset action
b4	Preset prohibit	Preset permit
b5 to b7	Undefined	
b8	No action	Error flag reset
b9	No action	YH output reset
b10	No action	YS output reset
b11	No action	YH output set
b12	No action	YS output set

- When b0 is set to ON and the DISABLE input terminal to OFF, the counter is permitted to start counting input pulses.
- Unless b1 is set to ON, YH (hardware compared output) does not turn ON.
- Unless b2 is set to ON, YS (software compared output) does not turn ON.
- When b3=ON, YS output is reset if YH output is set, and YH output is reset if YS output is set. When b3=OFF, YH and YS output act independently, and do not reset each other.
- When b4=OFF, preset function by the PRESET input terminal is disabled.
- When b8 is set to ON, all error flags are reset.
- When b9 is set to ON, YH output is reset.
- When b10 is set to ON, YS output is reset.
- When b11 is set to ON, YH output is set ON.
- When b12 is set to ON, YS output is set ON.

4) BFM #11, #10 Preset data

- Data to used as the initial value when the counter starts to count.
- Data becomes valid when b4 of BFM #4 is set to ON, and PRESET input terminal changes from OFF to ON. The default value of the counter is zero. You can change it by writing a value into BFM #11 and #10 or by using the command below.
- The initial counter value can also be set by writing the data directly into BFM #21 and #20 (current value of the counter).

5) BFM #13, #12 Comparison value for YH output, BFM #15, #14 Comparison value for YS output

- After comparing the current value of the counter with the value written in BFM #13 and #12, BFM #15 and #14, the hardware and software comparator in the FX2N-1HC outputs the comparison result.
- YH, YS output will not turn ON if you use PRESET or the TO instruction to set the counter value equal to the comparison value. It will turn ON only when a match occurs by the counting of input pulses.
- The YS comparison operation takes about 300µs, and if a match occurs, the output goes ON.
- Output occurs when the current value becomes equal to the compare value but only if b1 and b2 of BFM #4 are ON. Once an output is set, it remains ON until it is reset by b9 or b10 of BFM #4. If b3 of BFM #4 is ON, however, one of the outputs is reset when the other is set.

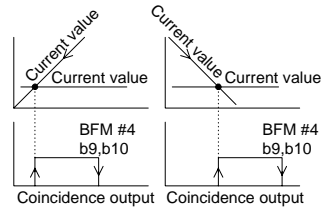

6) Counter current value (BFM #21, 20)

The current value of the counter can be read by the PLC. It will not be the correct value during high-speed operations because of the communication delay. The current value of the counter can be forcibly changed by writing a 32-bit value into the appropriate BFMs from the PLC.

7) Maximum count value (BFM #23, 22)

These store the maximum and minimum value reached by the counter. If the power is turned off, the stored data is cleared.

8) Comparison status (BFM #26)

BFM#26	When '0' (OFF)	When '1' (ON)	
YH	b0	Set value ≤ current value	Set value > current value
	b1	Set value ≠ current value	Set value = current value
	b2	Set value ≥ current value	Set value < current value

BFM#26	When '0' (OFF)	When '1' (ON)	
YS	b3	Set value ≤ current value	Set value > current value
	b4	Set value ≠ current value	Set value = current value
	b5	Set value ≥ current value	Set value < current value

BFM #26 is for reading only. Write commands from the programmable controller are ignored.

9) Terminal status (BFM #27)

BFM#26	When '0' (OFF)	When '1' (ON)
b0	PRESET input is OFF.	PRESET input is ON.
b1	DISABLE input is OFF.	DISABLE input is ON.

BFM#26	When '0' (OFF)	When '1' (ON)
b2	YH output is OFF.	YH output is ON.
b3	YS output is OFF.	YS output is ON.
b4-b15	Undefined	

10) BFM #29 Error status

Error status in the FX2N-1HC can be checked by reading the contents of b0 to b7 of BFM #29 to auxiliary relays of the PLC.

BFM#29	Error status	
b0	Set when any of b1 to b7 is ON.	
b1	Set when the value of the ring length is written incorrectly (other than K2 to K65,536).	
b2	Set when the preset value is written incorrectly.	
b3	Set when the compare value is written incorrectly.	
b4	Set when the current value is written in correctly.	
b5	Set when the counter overflows the upper limit.	
b6	Set when the counter overflows the lower limit.	
b7	Set when the FROM/TO command is used incorrectly.	
b8	Set when the counter mode (BFM#0) is written incorrectly.	When outside of K0 to K11
b9	Set when the BFM number is written incorrectly.	When outside of K0 to K31
b10-b15	Undefined	

These error flags can be reset by b8 of BFM #4.

11) Model identification code number BFM #30

This BFM stores the identification number for FX2N-1HC.

The identification number for the FX2N-1HC unit is K4010.

By reading this identification number, the user may create built-in checking routines to check whether the physical position of the FX2N-1HC matches to that of the software.

4. EXAMPLE PROGRAM

Please use the following program as a guide whenever you use the FX2N-1HC unit. Other instructions to read the current value of the counter, status etc. can be added as required.

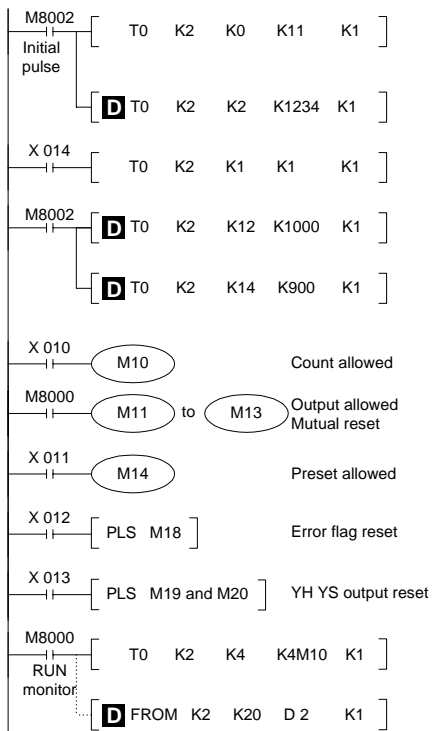

- K11 is written into BFM #0 of special function block No.2. The counter input is 16-bit 1-phase. Please use a pulse command for this initialization.
- K1234→BFM #3, #2 (special function block No.2)
The ring length can be specified when a 16-bit counter is specified.
- UP/DOWN direction should be specified for 1-phase 1-input software determined UP/DOWN counter.
- K1000→BFM #13, #12
Set the compare value for YH output.
- K900→BFM #15, #14
Set the compare value for YS output (not necessary if only YH output is used).
- Note that counting only occurs if count prohibit is OFF. Also, outputs will not be set from the counting process at all if the relevant output prohibit are set in the command register. Please reset the error flags and YH/YS output before you start. The mutual reset and preset initialization commands can be used as required.
- (M25 to M10) →BFM #4 (b15 to b0) command
- BFM (#21, #20)→Reads the current value to the data registers D3 and D2.

5. DIAGNOSTICS

5.1 Preliminary checks

- Check that the I/O wiring and extension cable of the FX2N-1HC are properly connected.
- 5V 90mA power is supplied from the main or extension units for the FX2N-1HC. Check that there is no power overload from this and other extension blocks.
- The counter works correctly only when data such as the counter mode (set with a pulse command), the TO command, the compare value, etc. are appropriately specified. Remember to initialize the count (BFM #4 b0), preset (BFM #4 b4), and output (BFM #4 b2, b1) prohibits. Reset the YH/YS outputs before you start.

5.2 Error checking

The following LEDs on the main panel of the FX2N-1HC may help you to troubleshoot the unit.

- φA, φB : Goes on/off as φA, φB input turn ON/OFF. It can be checked by rotating the encoder slowly.
- UP, DN : Lights up to indicate whether the counter is going up (UP) or down (DN).
- PRESET and DIS: The appropriate LED lights up when the PRESET terminal or the DISABLE terminal is ON.
- YH, YS : The appropriate LED lights up when YH/YS output is turned on.

You can check the error status by reading the content of BFM #29 to the PLC.

Error contents are shown in section 3.3 (10).



Note that inputting the pulse higher than the maximum frequency may cause mis-counting to 1HC or a FROM/TO error to the PLC main unit.

6. SYSTEM BLOCK DIAGRAM

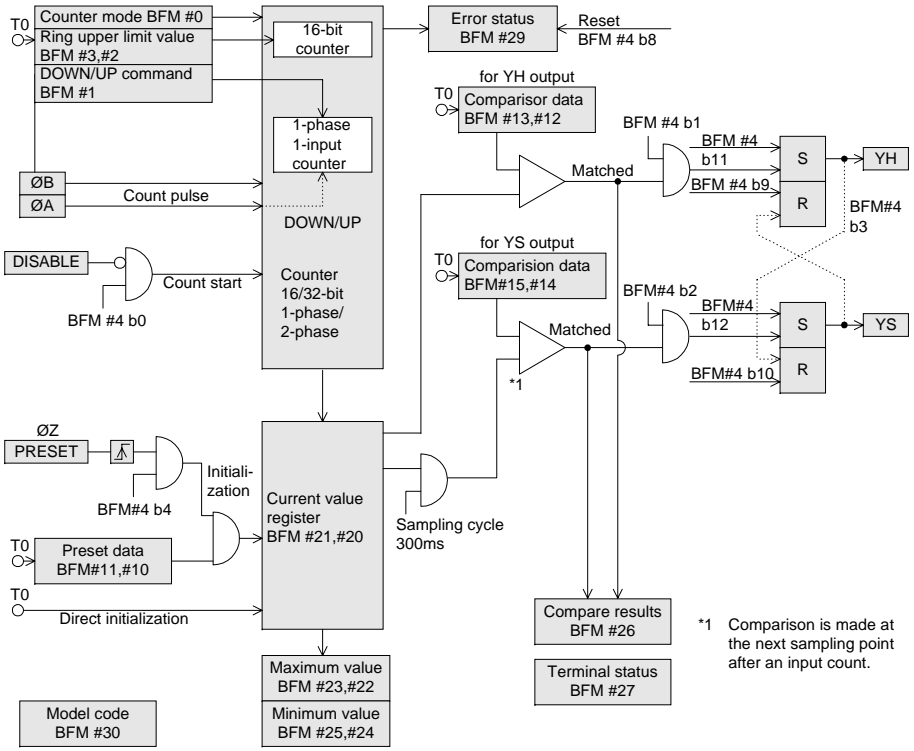

This manual confers no industrial property rights or any rights of any other kind, nor does it confer any patent licenses. Mitsubishi Electric Corporation cannot be held responsible for any problems involving industrial property rights which may occur as a result of using the contents noted in this manual.

Guidelines for the safety of the user and protection of the FX2N-1HC special function block

- This manual has been written to be used by trained and competent personnel. This is defined by the European directives for machinery, low voltage and EMC.
- If in doubt at any stage during the installation of the FX2N-1HC always consult a professional electrical engineer who is qualified and trained to the local and national standards. If in doubt about the operation or use of the FX2N-1HC please consult the nearest Mitsubishi Electric distributor.
- Under no circumstances will Mitsubishi Electric be liable or responsible for any consequential damage that may arise as a result of the installation or use of this equipment.
- All examples and diagrams shown in this manual are intended only as an aid to understanding the text, not to guarantee operation. Mitsubishi Electric will accept no responsibility for actual use of the product based on these illustrative examples.
- Owing to the very great variety in possible application of this equipment, you must satisfy yourself as to its suitability for your specific application.

Manual number : JY992D65401

Manual revision : E

Date : SEPTEMBER 2007

MITSUBISHI ELECTRIC CORPORATION

HEAD OFFICE : TOKYO BUILDING, 2-7-3 MARUNOUCHI, CHIYODA-KU, TOKYO 100-8310, JAPAN
HIMEJI WORKS : 840, CHIYODA CHO, HIMEJI, JAPAN

FX2N

FX2N-1HC SPECIAL FUNCTION BLOCK

USER'S GUIDE

JY992D65401E

This manual contains text, diagrams and explanations which will guide the reader in the correct installation and operation of the FX2N-1HC special function block and should be read and understood before attempting to install or use the unit.

Further information can be found in the FX PROGRAMMING MANUAL and FX2N, FX2NC, FX3U, FX3UC SERIES HARDWARE MANUAL.

1. INTRODUCTION

The hardware high-speed counter block is a 2-phase 50 kHz high-speed counter. It is a special function block for the FX2N, FX2NC, FX3U, FX3UC series PLC.

- FROM/TO instruction transfers the PLC data (i.e. parameters, comparing value and present value).
- The FX2N-1HC occupies 8 points of I/O on the FX2N, FX2NC, FX3U, FX3UC expansion bus. The 8 points can be allocated from either inputs or outputs.
- Differential-Line-Driver (AM26C31 or equivalent) and open collector output encoders are available for FX2N-1HC.
- The source of your input signal should be a 1 or 2 phase encoder. A 5V, 12V, or 24V power source can be used. An initial value setting command input (PRESET) and a count prohibit command input (DISABLE) are also available.
- The FX2N-1HC has two outputs. When the counter value coincides with an output compare value, the appropriate output is set ON. The output transistors are individually isolated to allow either sink or source connection methods.
- Various counter modes, such as 1-phase or 2-phase, 16-bit or 32-bit modes, can be selected using commands from the PLC. Allow the FX2N-1HC unit to run only after setting these mode parameters.

1.1 External dimensions

Mass (weight): Approx. 0.3 kg (0.66 lbs) Dimensions: mm (inches)
Accessories: Self-adhesive labels special block number identification.

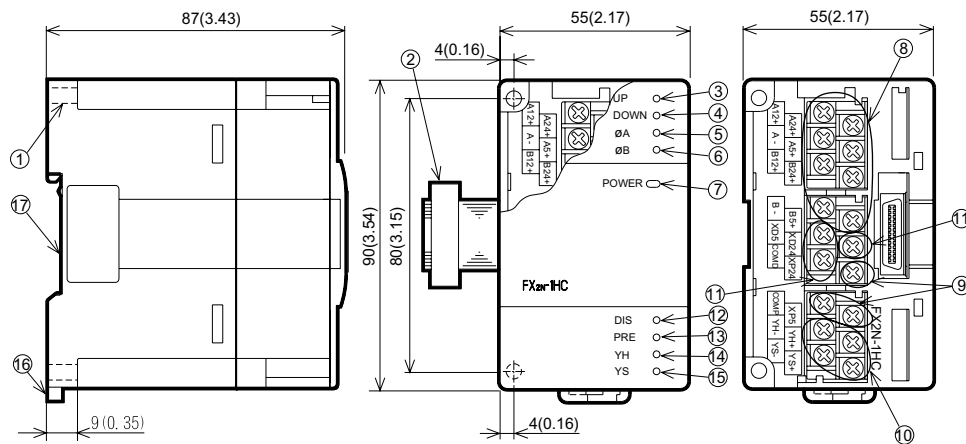

- Mounting hole 2-φ4.5 (0.18)
- Extension cable and connector
- UP LED
- DN (Down) LED
- φA LED
- φB LED
- POWER LED
- φA, φB terminal (M3 (0.12) screws)
- PRESET terminal (M3 (0.12) screws)

- YH-YS terminal (M3 (0.12) screws)
- DISABLE terminal (M3 (0.12) screws)
- DIS (DISABLE) LED
- PRESET LED
- YH LED
- YS LED
- DIN rail clip
- Attachment groove for 35 (1.38) wide DIN rail

Using the solderless termination

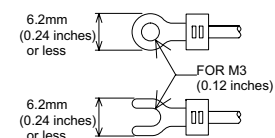

- Use crimp terminals of the dimensions specified in the left figure.
- Secure the terminals using a tightening torque of 0.5 to 0.8 N·m
- Wire only to the module terminals discussed in this manual. Leave all others vacant.

2. WIRING

PNP output encoders

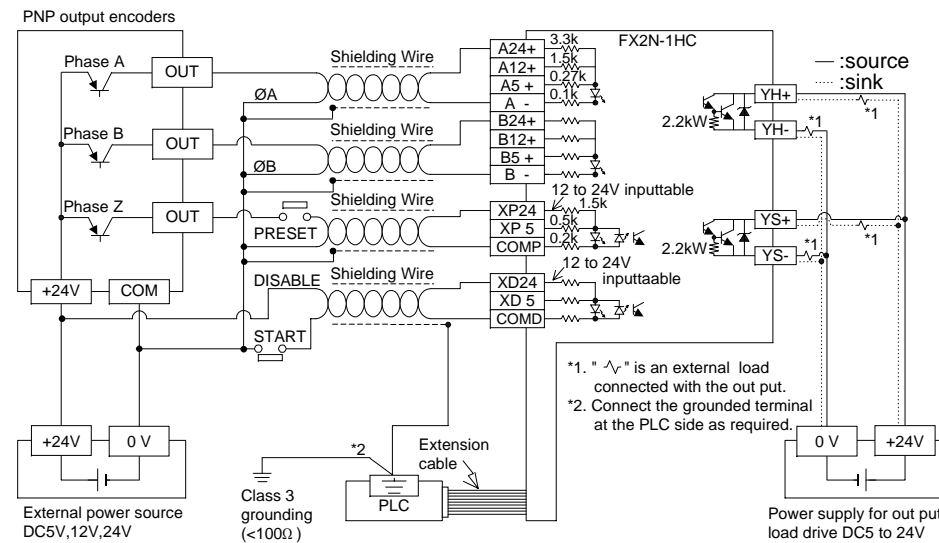

- * "Λ" is an external load connected with the out put.
- * Connect the grounded terminal at the PLC side as required.



If using on NPN output encoder please take care to match the polarity of the terminals of the encoder to those of the FX2N-1HC.

Differential-Line-Driver output encoders

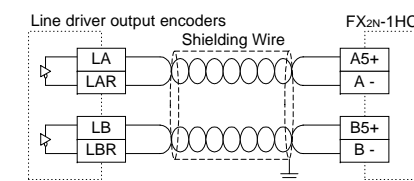

When applying the Differential-Line-Driver encoder (AM26C31 or equivalent) to FX2N-1HC, connect the encoder output with the 5V DC terminal as shown in the left figure.

Connect other terminals as shown in the PNP output encoder figure above.

3. SPECIFICATIONS

3.1 General specifications



Perform the dielectric withstand voltage test between the GND terminal and all the other terminals short-circuited.

Item	Specification
General specifications (excluding the following)	Same as those for the FX2N main unit
Dielectric withstand voltage	500V AC, 1min (between all terminals and ground)

3.2 Performance specifications

Item	1-phase input		2-phase input		
	1 input	2 inputs	1 edge count	2 edge count	4 edge count
Input signal	Phase A, Phase B	Phase A, Phase B	Phase A, Phase B	Phase A, Phase B	Phase A, Phase B
Signal level	[A24+],[B24+]: 24V DC±10% [A12+],[B12+]: 12V DC±10% [A5+],[B5+]: 3.0V to 5.5V DC	[A24+],[B24+]: 24V DC±10% [A12+],[B12+]: 12V DC±10% [A5+],[B5+]: 3.0V to 5.5V DC	[A24+],[B24+]: 24V DC±10% [A12+],[B12+]: 12V DC±10% [A5+],[B5+]: 3.0V to 5.5V DC	[A24+],[B24+]: 24V DC±10% [A12+],[B12+]: 12V DC±10% [A5+],[B5+]: 3.0V to 5.5V DC	[A24+],[B24+]: 24V DC±10% [A12+],[B12+]: 12V DC±10% [A5+],[B5+]: 3.0V to 5.5V DC
Input signal	PRESET, DISABLE	PRESET, DISABLE	PRESET, DISABLE	PRESET, DISABLE	PRESET, DISABLE
Input signal	[XP24],[XD24]: 10.8V to 26.4V DC [XP5],[XD5]: 5V DC±10%	[XP24],[XD24]: 10.8V to 26.4V DC [XP5],[XD5]: 5V DC±10%	[XP24],[XD24]: 10.8V to 26.4V DC [XP5],[XD5]: 5V DC±10%	[XP24],[XD24]: 10.8V to 26.4V DC [XP5],[XD5]: 5V DC±10%	[XP24],[XD24]: 10.8V to 26.4V DC [XP5],[XD5]: 5V DC±10%
Pulse shape	t1 : Rise/fall time is 3µs or less t2 : ON/OFF pulse 6µs or more (at 50kHz) t3 : Phase difference between A and B is 3.5µs or more (at 50kHz)	t1 : Rise/fall time is 3µs or less t2 : ON/OFF pulse 6µs or more (at 50kHz) t3 : Phase difference between A and B is 3.5µs or more (at 50kHz)	t1 : Rise/fall time is 3µs or less t2 : ON/OFF pulse 6µs or more (at 50kHz) t3 : Phase difference between A and B is 3.5µs or more (at 50kHz)	t1 : Rise/fall time is 3µs or less t2 : ON/OFF pulse 6µs or more (at 50kHz) t3 : Phase difference between A and B is 3.5µs or more (at 50kHz)	t1 : Rise/fall time is 3µs or less t2 : ON/OFF pulse 6µs or more (at 50kHz) t3 : Phase difference between A and B is 3.5µs or more (at 50kHz)
Format	Automatic UP/DOWN (however, when on 1-phase 1-input mode, UP/DOWN is determined by a PLC command or an input terminal.)	Automatic UP/DOWN (however, when on 1-phase 1-input mode, UP/DOWN is determined by a PLC command or an input terminal.)	Automatic UP/DOWN (however, when on 1-phase 1-input mode, UP/DOWN is determined by a PLC command or an input terminal.)	Automatic UP/DOWN (however, when on 1-phase 1-input mode, UP/DOWN is determined by a PLC command or an input terminal.)	Automatic UP/DOWN (however, when on 1-phase 1-input mode, UP/DOWN is determined by a PLC command or an input terminal.)
Range	When 32-bit is specified : -2,147,483,648 to +2,147,483,647 When 16-bit is specified : 0 to 65,535 (upper limit can be user specified)	When 32-bit is specified : -2,147,483,648 to +2,147,483,647 When 16-bit is specified : 0 to 65,535 (upper limit can be user specified)	When 32-bit is specified : -2,147,483,648 to +2,147,483,647 When 16-bit is specified : 0 to 65,535 (upper limit can be user specified)	When 32-bit is specified : -2,147,483,648 to +2,147,483,647 When 16-bit is specified : 0 to 65,535 (upper limit can be user specified)	When 32-bit is specified : -2,147,483,648 to +2,147,483,647 When 16-bit is specified : 0 to 65,535 (upper limit can be user specified)
Comparison Type	Each output is set when the present value of the counter matches with the compare value (which is transferred from the PLC), and is switched OFF by a reset command from the PLC. YH : Direct output processed by hardware. YS : Software processed output with worst delay time of 300µs. (Therefore, when the input frequency is 50 kHz, there is a worst case delay of 15 input pulses.)	Each output is set when the present value of the counter matches with the compare value (which is transferred from the PLC), and is switched OFF by a reset command from the PLC. YH : Direct output processed by hardware. YS : Software processed output with worst delay time of 300µs. (Therefore, when the input frequency is 50 kHz, there is a worst case delay of 15 input pulses.)	Each output is set when the present value of the counter matches with the compare value (which is transferred from the PLC), and is switched OFF by a reset command from the PLC. YH : Direct output processed by hardware. YS : Software processed output with worst delay time of 300µs. (Therefore, when the input frequency is 50 kHz, there is a worst case delay of 15 input pulses.)	Each output is set when the present value of the counter matches with the compare value (which is transferred from the PLC), and is switched OFF by a reset command from the PLC. YH : Direct output processed by hardware. YS : Software processed output with worst delay time of 300µs. (Therefore, when the input frequency is 50 kHz, there is a worst case delay of 15 input pulses.)	Each output is set when the present value of the counter matches with the compare value (which is transferred from the PLC), and is switched OFF by a reset command from the PLC. YH : Direct output processed by hardware. YS : Software processed output with worst delay time of 300µs. (Therefore, when the input frequency is 50 kHz, there is a worst case delay of 15 input pulses.)
Output signal	YH + : transistor output for YH output YH - : transistor output for YH output YS + : transistor output for YS output YS - : transistor output for YS output	YH + : transistor output for YH output YH - : transistor output for YH output YS + : transistor output for YS output YS - : transistor output for YS output	YH + : transistor output for YH output YH - : transistor output for YH output YS + : transistor output for YS output YS - : transistor output for YS output	YH + : transistor output for YH output YH - : transistor output for YH output YS + : transistor output for YS output YS - : transistor output for YS output	YH + : transistor output for YH output YH - : transistor output for YH output YS + : transistor output for YS output YS - : transistor output for YS output
Output capacity	5V to 24V DC 0.5A	5V to 24V DC 0.5A	5V to 24V DC 0.5A	5V to 24V DC 0.5A	5V to 24V DC 0.5A
I/O occupation	8 points taken from the FX2N expansion bus (can be either inputs or outputs)				
Power from base	5V DC 90mA (Internal power supply from main unit or powered extension unit)				

3.3 Buffer memories (BFM)

BFM number	Contents		
Write	#0	Counter mode K0 to K11	Default: K0
	#1	DOWN/UP command (1-phase 1-input mode)	Default: K0
	#3,#2	Ring length Upper/Lower	Default: K65,536
	#4	Command	Default: K0
	#11,#10	Preset data Upper/Lower	Default: K0
	#13,#12	YH compare value Upper/Lower	Default: K32,767
Write / Read	#15,#14	YS compare value Upper/Lower	Default: K32,767
	#21,#20	Counter current value Upper/Lower	Default: K0
	#23,#22	Maximum count value Upper/Lower	Default: K0
	#25,#24	Minimum count value Upper/Lower	Default: K0
Read	#26	Compare results	
	#27	Terminal status	
	#29	Error status	
	#30	Model identification code K4010	

#5-#9, #16-#19, #28, #31 are reserved.

1) BFM #0 Counter mode (K0 to K11), BFM #1 DOWN/UP command

Count modes	32 bits		16 bits	
	1 edge count	K0	K1	K2
2-phase input (phase difference pulse)	2 edge count	K2	K3	K4
	4 edge count	K4	K5	
	1-phase 2-input (add/subtract pulse)	K6	K7	
1-phase 1-input	Hardware UP/DOWN	K8	K9	
	Software UP/DOWN	K10	K11	

The counter mode is selected from the PLC. As shown below, values between K0 and K11 are written to buffer memory BFM #0 from the PLC. When a value is written to BFM #0 the contents of BFM #1 to BFM #31 are reset to default values. When setting this value use a **TOP** (pulsed) instruction use M8002 (initial pulse) to drive the **TO** instruction. A continuous command is not allowed.

a) 32-bit counter modes

A 32-bit binary counter which executes UP/DOWN counting will change from the lower limit value to the upper limit value or the upper limit value to the lower limit value when overflow occurs. Both the upper and lower limit values are fixed values: the upper limit value is +2,147,483,647, and the lower limit value is -2,147,483,648.

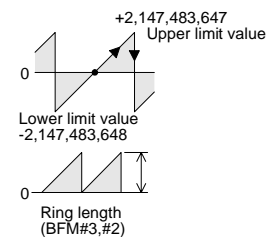

b) 16-bit counter modes

A 16-bit binary counter handles only positive values from 0 to 65,535. Changes to zero from the upper limit value or to the upper limit value from zero when overflow occurs; the upper limit value is determined by BFM#3 and #2.

c) 1-phase 1-input counter (K8 to K11)

- Hardware UP/DOWN (K8, K9)
- Software UP/DOWN (K10, K11)

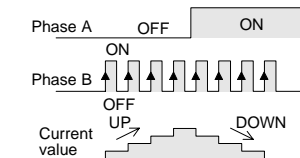

- Software UP/DOWN (K10, K11)

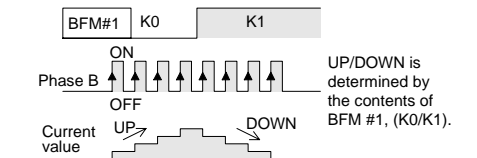

d) 1-phase 2-input counter (K6, K7)

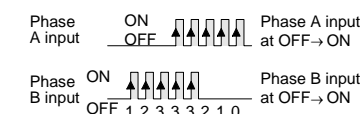

If both phase A and phase B inputs are received simultaneously, the counter value does not change.

e) 2-phase counter (K0 to K5)

- 1 edge-count (K0, K1)
- 2 edge-count (K2, K3)
- 4 edge-count (K4, K5)

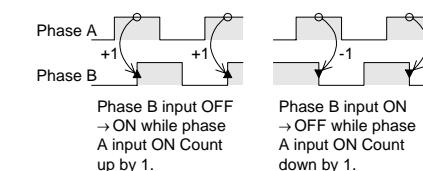

- 2 edge-count (K2, K3)

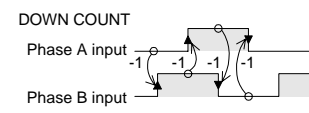
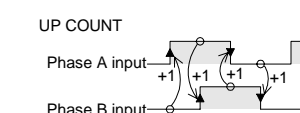
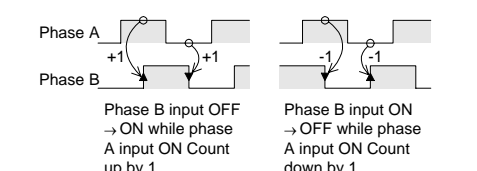

2) BFM #3, #2 Ring length

Stores the data that specifies the length of the 16-bit counter (default: K65,536).



In the above example, K100 is written into BFMs #3 and #2 of special block No.2 as a 32-bit binary value (BFM #3 = 0, BFM #2 = 100). Permitted values: K2 to K65,536.

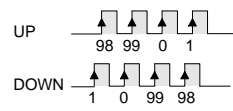

When ring length K100 is specified, the value of the counter changes as shown above.

Note: Write counter data with (D) TO

- Count data is always handled as a pair from two 16-bit values in this special function block. 16-bit 2's complement value stored in the registers of the PLC cannot be used.
- When you are writing a positive value between K32,768 and K65,535, the data should be treated as a 32-bit value even when a 16-bit ring counter is used.
- When transferring counter data to/from this special function block, always use the 32-bit forms of the FROM/TO instructions ((D) FROM, (D) TO).

3) BFM #4 Command

BFM#4	When '0'(OFF)	When '1'(ON)
b0	Count prohibit	Count permit
b1	YH output prohibit	YH output permit
b2	YS output prohibit	YS output permit
b3	YH/YS independent action	Mutual reset action
b4	Preset prohibit	Preset permit
b5 to b7	Undefined	
b8	No action	Error flag reset
b9	No action	YH output reset
b10	No action	YS output reset
b11	No action	YH output set
b12	No action	YS output set

- When b0 is set to ON and the DISABLE input terminal to OFF, the counter is permitted to start counting input pulses.
- Unless b1 is set to ON, YH (hardware compared output) does not turn ON.
- Unless b2 is set to ON, YS (software compared output) does not turn ON.
- When b3=ON, YS output is reset if YH output is set, and YH output is reset if YS output is set. When b3=OFF, YH and YS output act independently, and do not reset each other.
- When b4=OFF, preset function by the PRESET input terminal is disabled.
- When b8 is set to ON, all error flags are reset.
- When b9 is set to ON, YH output is reset.
- When b10 is set to ON, YS output is reset.
- When b11 is set to ON, YH output is set ON.
- When b12 is set to ON, YS output is set ON.

4) BFM #11, #10 Preset data

- Data to be used as the initial value when the counter starts to count.
- Data becomes valid when b4 of BFM #4 is set to ON, and PRESET input terminal changes from OFF to ON. The default value of the counter is zero. You can change it by writing a value into BFM #11 and #10 or by using the command below.
- The initial counter value can also be set by writing the data directly into BFM #21 and #20 (current value of the counter).

5) BFM #13, #12 Comparison value for YH output, BFM #15, #14 Comparison value for YS output

- After comparing the current value of the counter with the value written in BFM #13 and #12, BFM #15 and #14, the hardware and software comparator in the FX2N-1HC outputs the comparison result.
- YH, YS output will not turn ON if you use PRESET or the TO instruction to set the counter value equal to the comparison value. It will turn ON only when a match occurs by the counting of input pulses.
- The YS comparison operation takes about 300µs, and if a match occurs, the output goes ON.
- Output occurs when the current value becomes equal to the compare value but only if b1 and b2 of BFM #4 are ON. Once an output is set, it remains ON until it is reset by b9 or b10 of BFM #4. If b3 of BFM #4 is ON, however, one of the outputs is reset when the other is set.

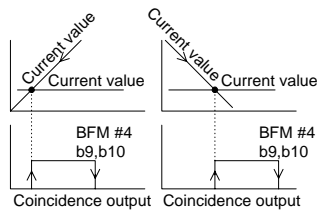

6) Counter current value (BFM #21, 20)

The current value of the counter can be read by the PLC. It will not be the correct value during high-speed operations because of the communication delay. The current value of the counter can be forcibly changed by writing a 32-bit value into the appropriate BFMs from the PLC.

7) Maximum count value (BFM #23, 22)

These store the maximum and minimum value reached by the counter. If the power is turned off, the stored data is cleared.

8) Comparison status (BFM #26)

BFM#26	When '0' (OFF)	When '1' (ON)
YH	b0	Set value ≤ current value
	b1	Set value ≠ current value
	b2	Set value ≥ current value

BFM#26	When '0' (OFF)	When '1' (ON)
YS	b3	Set value ≤ current value
	b4	Set value ≠ current value
	b5	Set value ≥ current value

BFM #26 is for reading only. Write commands from the programmable controller are ignored.

9) Terminal status (BFM #27)

BFM#26	When '0' (OFF)	When '1' (ON)
b0	PRESET input is OFF.	PRESET input is ON.
b1	DISABLE input is OFF.	DISABLE input is ON.

BFM#26	When '0' (OFF)	When '1' (ON)
b2	YH output is OFF.	YH output is ON.
b3	YS output is OFF.	YS output is ON.
b4-b15	Undefined	

10) BFM #29 Error status

Error status in the FX2N-1HC can be checked by reading the contents of b0 to b7 of BFM #29 to auxiliary relays of the PLC.

BFM#29	Error status	
b0	Set when any of b1 to b7 is ON.	
b1	Set when the value of the ring length is written incorrectly (other than K2 to K65,536).	
b2	Set when the preset value is written incorrectly.	
b3	Set when the compare value is written incorrectly.	
b4	Set when the current value is written in correctly.	
b5	Set when the counter overflows the upper limit.	
b6	Set when the counter overflows the lower limit.	
b7	Set when the FROM/TO command is used incorrectly.	
b8	Set when the counter mode (BFM#0) is written incorrectly.	
b9	Set when the BFM number is written incorrectly.	
b10-b15	Undefined	

These error flags can be reset by b8 of BFM #4.

11) Model identification code number BFM #30

This BFM stores the identification number for FX2N-1HC. The identification number for the FX2N-1HC unit is K4010. By reading this identification number, the user may create built-in checking routines to check whether the physical position of the FX2N-1HC matches to that of the software.

4. EXAMPLE PROGRAM

Please use the following program as a guide whenever you use the FX2N-1HC unit. Other instructions to read the current value of the counter, status etc. can be added as required.

